



# Vehiclehub Pro

## VPA-B222



- **OWNER'S MANUAL**  
Please read before using this equipment.
- **MODE D'EMPLOI**  
Veuillez lire avant d'utiliser cet appareil.
- **MANUAL DE OPERACIÓN**  
Léalo antes de utilizar este equipo.

**ALPINE ELECTRONICS MARKETING, INC.**  
1-1-8 Nishi Gotanda,  
Shinagawa-ku,  
Tokyo 141-0031, Japan  
Phone 03-5496-8231

**ALPINE ELECTRONICS OF AMERICA, INC.**  
19145 Gramercy Place, Torrance,  
California 90501, U.S.A.  
Phone 1-800-ALPINE-1 (1-800-257-4631)

**ALPINE ELECTRONICS OF CANADA, INC.**  
777 Supertest Road, Toronto,  
Ontario M3J 2M9, Canada  
Phone 1-800-ALPINE-1 (1-800-257-4631)

**ALPINE ELECTRONICS OF AUSTRALIA PTY. LTD.**  
161-165 Princes Highway, Hallam  
Victoria 3803, Australia  
Phone 03-8787-1200

**ALPINE ELECTRONICS GmbH**  
Frankfurter Ring 117, 80807 München, Germany  
Phone 089-32 42 640

**ALPINE ELECTRONICS OF U.K. LTD.**  
Alpine House  
Fletchamstead Highway, Coventry CV4 9TW, U.K.  
Phone 0870-33 33 763

**ALPINE ELECTRONICS FRANCE S.A.R.L.**  
(RCS PONTOISE B 338 101 280)  
98, Rue de la Belle Etoile, Z.I. Paris Nord II,  
B.P. 50016, 95945 Roissy Charles de Gaulle  
Cedex, France  
Phone 01-48638989

**ALPINE ITALIA S.p.A.**  
Viale C. Colombo 8, 20090 Trezzano  
Sul Naviglio (MI), Italy  
Phone 02-484781

**ALPINE ELECTRONICS DE ESPAÑA, S.A.**  
Portal de Gamarra 36, Pabellón, 32  
01013 Vitoria (Alava)-APDO 133, Spain  
Phone 945-283588

**ALPINE ELECTRONICS (BENELUX) GmbH**  
Leuvensesteenweg 510-B6,  
1930 Zaventem, Belgium  
Phone 02-725-13 15

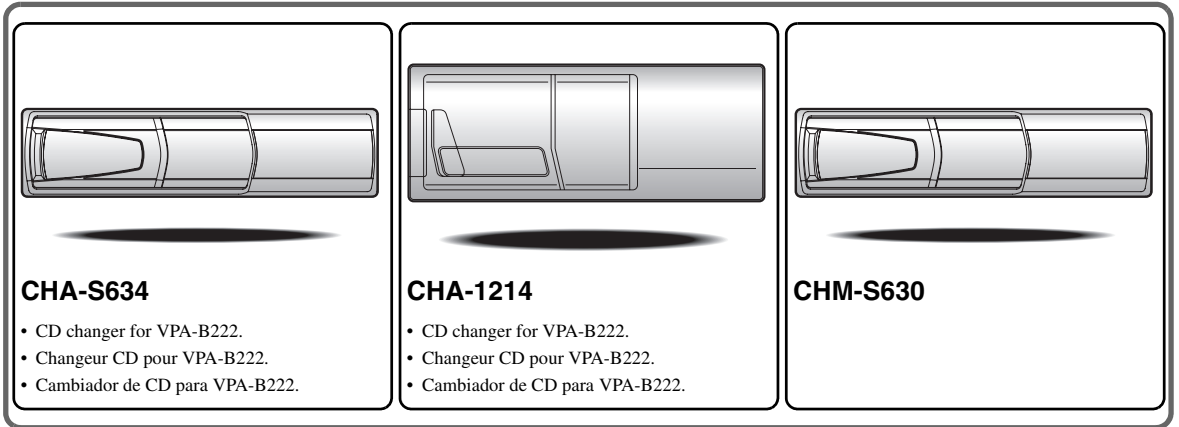

## Alpine CD Changers Give You More!

***More musical selections, more versatility, more convenience.***

The CHA-S634 is a high-performance 6-disc changer with a new M DAC, CD-R/RW PLAY BACK, MP3 PLAY BACK and CD TEXT. The CHA-1214 Ai-NET model holds 12 discs, and the CHM-S630 M-Bus model is a super-compact 6-disc changer with a CD-R/RW PLAY BACK.

## Changeurs de CD Alpine : vous avez le choix!

***Plus de sélections musicales, plus de souplesse, plus de confort.***

Le modèle CHA-S634 est un changeur 6 disques ultra performant équipé des nouvelles fonctions M DAC, CD-R/RW PLAY BACK, MP3 PLAY BACK et CD TEXT. Le modèle CHA-1214 Ai-NET contient 12 disques. Le modèle CHM-S630 M-Bus est un changeur 6 disques super compact doté de la fonction CD-R/RW PLAY BACK.

## ¡Los cambiadores Alpine de CD le ofrecen más!

***Más selecciones musicales, más versatilidad y más ventajas.***

CHA-S634 es un cambiador de seis discos de alto rendimiento con nuevo M DAC, CD-R/RW PLAY BACK, MP3 PLAY BACK y CD TEXT. El modelo CHA-1214 Ai-NET alberga 12 discos y el modelo CHM-S630 M-Bus es un cambiador de seis discos de tamaño reducido con un CD-R/RW PLAY BACK.

# Contents

## Operating Instructions

### WARNING

**WARNING** ..... 4  
**CAUTION** ..... 4  
**PRECAUTIONS** ..... 5

### Getting Started

Feature ..... 6  
 Accessory List ..... 6  
 Initial System Start-Up ..... 6  
 Turning Power On or Off ..... 6  
     Displaying the Unit Source on the  
     Monitor ..... 6  
 Switching a Source ..... 7  
 Adjusting the Volume ..... 7  
 Lowering Volume Quickly ..... 7

### Radio

Listening to Radio ..... 7  
 Manual Storing of Station Presets ..... 8  
 Automatic Memory of Station Presets ..... 8  
 Tuning to Preset Stations ..... 8  
 Setting Analog Mode  
 (HD Radio mode only) ..... 8  
 Changing the Display  
 (HD Radio mode only) ..... 9

### Other Useful Features

Adjusting the Audio ..... 9  
     Adjusting the Balance ..... 10  
     Adjusting the Fader ..... 10  
     Setting the Treble Control ..... 10  
     Setting the Bass Control ..... 10  
     Adjusting the Subwoofer Level ..... 10  
     Tuning Loudness ON or OFF ..... 10

Tuning Defeat ON or OFF ..... 10  
 Adjusting Volume of GUIDE Voice ..... 10  
 Rear Entertainment Function ..... 11  
     Switching the function of the remote  
     sensor ..... 11

### Setup

#### GENERAL Setup

General Setup Operation ..... 12  
 Demonstration Function ..... 12  
 Setting the Time Display ..... 12  
 Setting the Time ..... 13  
 Setting Daylight Saving Time ..... 13  
 Sound (Beep) Guide Function ..... 13  
 Turning the Commander Vibration  
     ON or OFF ..... 13  
 Setting the Scroll ..... 13

#### SYSTEM Setup

System Setup Operation ..... 13  
 Using the Speaker Input ..... 14  
     Setting the Speaker Input Mode ..... 14  
     Displaying the Speaker Input Volume  
     Level ..... 14  
     Setting the Navigation/Speaker Input Voice  
     Interruption ..... 14  
     Adjusting the Speaker Input's Interruption  
     Detection Level ..... 14  
     Adjusting the Speaker Input Voice Interruption  
     Level ..... 14  
     Setting the Interrupt Type of the Speaker Input  
     Voice ..... 15  
     Setting the Channel of the Speaker Interruption  
     Detection ..... 15  
 Connecting the Navigation ..... 15  
     Setting the Navigation Mode ..... 15  
     Navigation Audio Interruption Volume  
     Adjustment ..... 15  
 Connecting an External Input Device  
 (AUX) ..... 15  
     Setting the AUX Mode ..... 15  
     Naming External Devices ..... 15

Adjusting the External Input Audio Level .....	15
Connecting the Rear Monitor .....	16
Setting of the External Monitor Output .....	16
Setting the VISUALIZER Mode Display ...	16
Connecting a Subwoofer .....	16
Subwoofer On and Off .....	16
Setting the Commander .....	16
Setting the Color of the Commander Button illumination .....	16
Turning the Commander Button illumination on and off .....	16
Adjusting the Brightness of the Commander Button illumination .....	16
Setting the Others .....	16
Setting the External Device Interrupt Mode .....	16
Adjusting the display position .....	17
Setting the Auxiliary Data Field Display ...	17

## **CD/MP3/WMA Operation (Optional)**

Playing CD/MP3/WMA .....	17
Folder/File Search .....	18
M.I.X. (Random Play) .....	18
Repeat Play .....	18

## **DVD/Video CD Operation (Optional)**

Playing DVD/Video CD .....	19
To display the DVD mode screen .....	20
If a menu screen appears .....	20
Playing Still Frames (Pausing) .....	20
Finding the Beginnings of Chapters or Tracks .....	20
Fast-forwarding/Fast-reversing .....	20
Displaying the Top Menu Screen (DVD only) .....	21
Changing Discs (only when DVD changer is connected) .....	21
Stopping Playback (PRE STOP) .....	21
Stopping Playback .....	21
Chapter/Track/Title Repeat Playback .....	21
Switching the Audio Tracks .....	21

Switching the Subtitles (Subtitle Language) (DVD only) .....	22
Switching the Angle (DVD only) .....	22
Switching from the disc menu .....	22

## **SAT Radio Receiver (Optional)**

Receiving Channels with the SAT Receiver ...	23
Tuning in to Categorized Programs .....	23
Changing the Display .....	23
Checking the SAT Radio ID Number .....	24
Storing Channel Presets .....	24
Receiving Stored Channels .....	24
Category/Channel Search Function .....	25
Storing Weather or Traffic information from SAT Radio .....	25
Receiving Weather or Traffic Information from SAT Radio .....	25

## **iPod® (Optional)**

Playback .....	25
Searching for a desired Song .....	26
Searching by Playlist .....	26
Searching by artist name .....	26
Searching by album name .....	26
Searching by Song Name .....	27
Select Playlist/Artist/Album .....	27
Random Play Shuffle (M.I.X.) .....	27
Repeat Play .....	27

## **Navigation System (Optional)**

Displaying the Navigation Screen .....	28
Changing the Navigation operation mode .....	28
Map Screen Function .....	28
Displaying the Current Position .....	28
Scrolling the Map .....	28
Changing the Map Scale .....	28
Menu Screen Function .....	28

## **TV Operation (Optional)**

Operating TV Unit .....	29
Automatic Memory of Channel Presets .....	29

Switching Audio .....	29
<b>Auxiliary Device (Optional)</b>	
Operating Auxiliary Devices (Optional) .....	30
<b>Factory System</b>	
Operating Factory System (Speaker Input mode) .....	31
<b>HDD Player Operation (Optional)</b>	
Listening to Music of HDD .....	31
<b>External Audio Processor (Optional)</b>	
Adjustment Procedure for Dolby Surround ...	32
Setting the Speakers .....	33
Set MX Mode of the External Audio Processor .....	33
X-OVER Adjustment .....	33
Performing Time Correction Manually (TCR) .....	34
Phase Switching .....	35
Graphic Equalizer Adjustments .....	35
Parametric Equalizer Adjustments .....	35
Setting Bass Sound Control .....	36
Setting Bass Compressor .....	36
Setting Bass Focus .....	36
Speaker Setup .....	36
Setting of Dolby Digital .....	37
Adjusting the acoustic image .....	37
Mixing bass sound to the rear channel .....	37
Achieving powerful high volume sound .....	37
Adjusting the speaker levels .....	37
Adjusting the DVD Level .....	38
Storing Settings in the Memory .....	38
Calling up the Preset Memory .....	38
Using the Pro Logic II Mode .....	38
Linear PCM Setting .....	39

## Soft button operation

Basic operation .....	39
Radio Operation .....	40
Setup Operation .....	40
CD/MP3/WMA Operation .....	41
DVD/Video CD Operation .....	41
SAT Radio Operation .....	42
iPod® Operation .....	43
TV Operation .....	44
HDD Player Operation .....	44

## Information

In Case of Difficulty .....	45
Specifications .....	47

---

# Installation and Connections

<b>Warning</b> .....	<b>48</b>
<b>Caution</b> .....	<b>48</b>
<b>Precautions</b> .....	<b>48</b>
Installation .....	49
Connections (VPA-B222 Wiring Diagram) ....	52
System Example .....	54

## LIMITED WARRANTY

---

---

# Operating Instructions

## WARNING



This symbol means important instructions. Failure to heed them can result in serious injury or death.

---

### **INSTALL THE PRODUCT CORRECTLY SO THAT THE DRIVER CANNOT WATCH TV/VIDEO UNLESS THE VEHICLE IS STOPPED AND THE EMERGENCY BRAKE IS APPLIED.**

It is dangerous (and illegal in many states) for the driver to watch TV/Video while driving a vehicle. Installing this product incorrectly enables the driver to watch TV/Video while driving. This may cause a distraction, preventing the driver from looking ahead, thus causing an accident. The driver or other people could be severely injured.

---

### **DO NOT WATCH VIDEO WHILE DRIVING.**

Watching the video may distract the driver from looking ahead of the vehicle and cause an accident.

---

### **DO NOT OPERATE ANY FUNCTION THAT TAKES YOUR ATTENTION AWAY FROM SAFELY DRIVING YOUR VEHICLE.**

Any function that requires your prolonged attention should only be performed after coming to a complete stop. Always stop the vehicle in a safe location before performing these functions. Failure to do so may result in an accident.

---

### **KEEP THE VOLUME AT A LEVEL WHERE YOU CAN STILL HEAR OUTSIDE NOISE WHILE DRIVING.**

Failure to do so may result in an accident.

---

### **MINIMIZE DISPLAY VIEWING WHILE DRIVING.**

Viewing the display may distract the driver from looking ahead of the vehicle and cause an accident.

---

### **DO NOT DISASSEMBLE OR ALTER.**

Doing so may result in an accident, fire or electric shock.

---

### **USE ONLY IN CARS WITH A 12 VOLT NEGATIVE GROUND.**

(Check with your dealer if you are not sure.) Failure to do so may result in fire, etc.

---

### **KEEP SMALL OBJECTS SUCH AS BATTERIES OUT OF THE REACH OF CHILDREN.**

Swallowing them may result in serious injury. If swallowed, consult a physician immediately.

---

### **USE THE CORRECT AMPERE RATING WHEN REPLACING FUSES.**

Failure to do so may result in fire or electric shock.

---

### **DO NOT BLOCK VENTS OR RADIATOR PANELS.**

Doing so may cause heat to build up inside and may result in fire.

---

### **USE THIS PRODUCT FOR MOBILE 12V APPLICATIONS.**

Use for other than its designed application may result in fire, electric shock or other injury.



This symbol means important instructions. Failure to heed them can result in injury or material property damage.

---

### **HALT USE IMMEDIATELY IF A PROBLEM APPEARS.**

Failure to do so may cause personal injury or damage to the product. Return it to your authorized Alpine dealer or the nearest Alpine Service Center for repairing.



# PRECAUTIONS

---

## Product Cleaning

Use a soft dry cloth for periodic cleaning of the product. For more severe stains, please dampen the cloth with water only. Anything else has the chance of dissolving the paint or damaging the plastic.

---

## Temperature

Be sure the temperature inside the vehicle is between +45°C (+113°F) and 0°C (+32°F) before turning your unit on.

---

## Moisture Condensation

You may notice the disc playback sound wavering due to condensation. If this happens, remove the disc from the player and wait about an hour for the moisture to evaporate.

---

## Maintenance

If you have problems, do not attempt to repair the unit yourself. Return it to your Alpine dealer or the nearest Alpine Service Station for servicing.

---

## Installation Location

Make sure the VPA-B222 will not be installed in a location subjected to:

- Direct sun and heat
  - High humidity and water
  - Excessive dust
  - Excessive vibrations
- 

Alpine products equipped with the Ai-NET bus, connected to the VPA-B222, can be operated from the VPA-B222. Depending on the products connected, the functions and displays will vary. For details, consult your Alpine dealer.

---

Operation of some of the functions of this unit is very complex. Because of this, it was deemed necessary to place these functions into a special screen. This will restrict operation of these functions to times when the vehicle is parked. This ensures the focus of the driver's attention will be on the road and not on the VPA-B222. This has been done for the safety of the driver and passengers. Audio Processor Adjustments cannot be made if the car is moving. The car must be parked and the parking brake must be engaged for the procedure described in the Owner's Manual to be valid. The warning "CAN'T OPERATE WHILE DRIVING," will be displayed if any attempts are made to perform these operations while driving.

---

- *Apple, the Apple logo and iPod are trademarks of Apple Computer, Inc., registered in the U.S. and other countries.*
- *HD Radio™ Technology Manufactured Under License From iBiquity Digital Corporation. iBiquity Digital and the HD Radio and HD Symbols are trademarks of iBiquity Digital Corporation. U.S. and Foreign Patents.*

# Getting Started

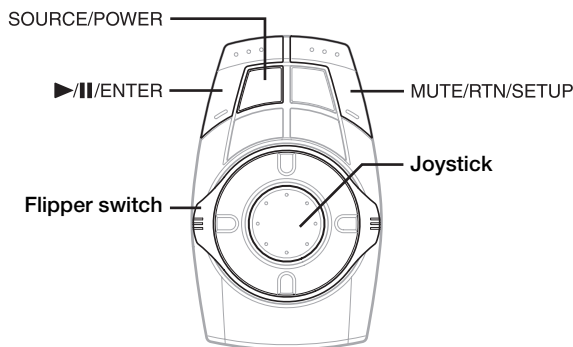

Operation is carried out by the commander. If an Alpine touch panel monitor is connected to this unit, the touch buttons appear in the display to enable touch operation.

This manual explains operation using the commander. For details of the touch operation, refer to "Soft button operation" on page 39.

- The commander vibrates when an operation is performed. Refer to "Turning the Commander Vibration ON or OFF" (page 13).

## Feature

If an Alpine Ai-NET compatible products (DVD player, DVD/CD changer), or iPod using the FULLSPEED™ Connection Cable is connected to the VPA-B222, it can be controlled from the commander and displayed on the external monitor. If an optional Alpine Navigation System is connected to the VPA-B222, the Navigation screen will be displayed on the external monitor, and its operation can be performed. For details on the function of connected devices, refer to the Owner's Manual.

## Accessory List

Main unit.....	1
Power cable.....	1
Parking brake sub-lead .....	1
Factory System Cable .....	1
Pinch connector .....	6
Bracket .....	2
Tapping screw (M4 × 14).....	4
Pan screw (M4 × 8) .....	4
Velcro fastener .....	2
RGB cable (3M) .....	1
RCA extension cable (3M) .....	1
Antenna extension cable (3M).....	1
Commander .....	1
Holder.....	1
Commander connection cable (3M) .....	1
Double-sided adhesive tape .....	1
Reinforcement screw.....	3
Cable clamp .....	3

## Initial System Start-Up

Be sure to press the RESET button when using the unit for the first time, after installing the CD changer, after changing the car battery, etc.

- 1 Turn off the unit power.
- 2 Press **RESET** with a ball-point pen or similar pointed object.

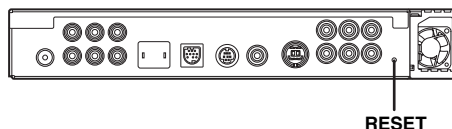

## Turning Power On or Off

Some of this unit's functions cannot be performed while the vehicle is in motion. Be sure to stop your vehicle in a safe location and apply the parking brake, before attempting these operations.

- 1 Press **SOURCE/POWER** to turn on the unit.
  - The unit can be turned on by pressing any button.
- 2 Press and hold **SOURCE/POWER** for at least 2 seconds to turn off the unit.

## Displaying the Unit Source on the Monitor

By selecting the image source on the unit, it can be displayed on a connected monitor. For operation, refer to the Owner's Manual of the monitor.

### If an Alpine monitor is connected (RGB connection)

- 1 Recall the navigation mode by selecting the image source on the monitor.  
The source of the unit is displayed.



## Switching a Source

### 1 Press **SOURCE/POWER**.

The source selection screen is displayed.

#### Screen example

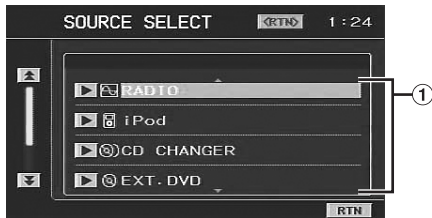

- ① Displays source modes that can be selected (The kind of source modes that are displayed varies depending on connection and setting)

### 2 Press the joystick up or down to select the desired source, then press **▶/II/ENTER**.

The selected main source screen is displayed.

- In the source selection screen mode, press **MUTE/RTN/SETUP** to return to the previous screen.

## Adjusting the Volume

Turn the **flipper switch** clockwise or counterclockwise to adjust the volume.

Clockwise: Volume up  
Counterclockwise: Volume down  
Volume: 0 - 35

## Lowering Volume Quickly

Activating this function will instantly lower the volume level.

**Press MUTE/RTN/SETUP to activate the MUTE mode.**

The audio level decreases.  
During mute, the volume level indicator will blink.

Pressing **MUTE/RTN/SETUP** again brings the audio back to its previous level.

## Radio

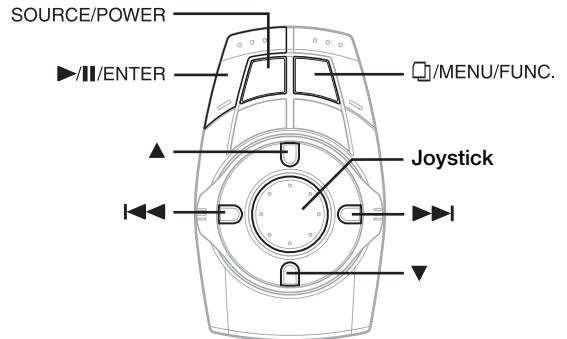

This unit cannot receive HD Radio™ signals (digital terrestrial radio). In order to activate the digital radio functions described below, an optional HD Radio Tuner module must be connected through the Ai-NET bus.

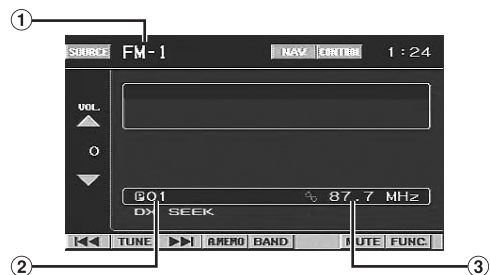

- ① Band display  
② Preset number display  
③ Frequency display

## Listening to Radio

### 1 Press **SOURCE/POWER**.

The source selection screen is displayed.

### 2 Press the joystick up or down to select **RADIO**, then press **▶/II/ENTER**.

### 3 Press and hold **▲** for at least 2 seconds repeatedly until the desired radio band is displayed.

FM-1 → FM-2 → AM → FM-1

### 4 Press **▶/II/ENTER** to select the tuning mode.

DX SEEK → SEEK → (OFF) → DX SEEK

- The initial mode is Distance mode.

#### **DX SEEK (Distance mode):**

Both strong and weak stations will be automatically tuned in (Automatic Seek Tuning).

#### **SEEK (Local mode):**

Only strong stations will be automatically tuned in (Automatic Seek Tuning).

#### **OFF (Manual mode):**

The frequency is manually tuned in steps (Manual tuning).

- 5 Press **◀◀** or **▶▶** to tune in the desired station.  
Holding down **◀◀** or **▶▶** will change the frequency continuously.

- “DIGITAL” is displayed when a digital radio station is received.

---

## Manual Storing of Station Presets

---

- 1 Select the radio band and tune in a desired radio station you wish to store in the preset memory.
- 2 Press and hold **□/MENU/FUNC.** for at least 2 seconds.  
The FUNCTION screen is displayed.
- 3 Press the joystick up or down to select **PRESET MEMORY**, then press the joystick right.
- 4 Press the joystick up or down to select any one of the preset numbers **PRESET1** through **PRESET6**, then press **▶/II/ENTER**.  
The selected station is stored.  
The display shows the band, preset number and station frequency memorized.

- A total of 18 stations can be stored in the preset memory (6 stations for each band; FM-1, FM-2 and AM).
- If you store a station in a preset memory which already has a station, the current station will be cleared and replaced with the new station.

---

## Automatic Memory of Station Presets

---

- 1 Press and hold **▲** for at least 2 seconds repeatedly until the desired radio band is displayed.
  - 2 Press and hold **▶/II/ENTER** for at least 2 seconds.  
The frequency on the display continues to change while the automatic memory is in progress. The tuner will automatically seek and store 6 strong stations in the selected band. They will be stored into PRESET1 to PRESET6 in order of signal strength.  
When the automatic memory has been completed, the tuner goes to the station stored in preset location No. 1.
- If no stations are stored, the tuner will return to the original station you were listening to before the auto memory procedure began.

---

## Tuning to Preset Stations

---

- 1 Press and hold **▲** for at least 2 seconds repeatedly until the desired band is displayed.

### Changing Stations by the Commander

- 2 Press **▲** or **▼** to select a preset number (P01 to P06).  
The selected station is received.

### Recalling by the FUNCTION screen

- 2 Press and hold **□/MENU/FUNC.** for at least 2 seconds.  
The FUNCTION screen is displayed.
- 3 Press the joystick up or down to select **PRESET CALL**, then press the joystick right.
- 4 Press the joystick up or down to select any one of the preset numbers **PRESET1** through **PRESET6**, then press **▶/II/ENTER**.  
The preset station is received.  
The display shows the band, preset number and frequency of the station selected.

---

## Setting Analog Mode (HD Radio mode only)

---

While receiving HD radio, you can switch to analog signal mode, even in areas that receive digital radio station signals.

- 1 Press and hold **□/MENU/FUNC.** for at least 2 seconds.  
The FUNCTION screen is displayed.
- 2 Press the joystick up or down to select **ANALOG MODE**, then press the joystick right.
- 3 Press the joystick up or down to select **ON**, then press **▶/II/ENTER**.

## Changing the Display (HD Radio mode only)

Text information, such as Station name, Song title, Artist, etc., is displayed while receiving a digital radio station.

- 1 Press and hold **MENU/FUNC.** for at least 2 seconds.  
The FUNCTION screen is displayed.
- 2 Press the **joystick up or down** to select the **INFO.**, then press **►/II/ENTER.**  
Each time you perform the above operations, the display changes as shown below.

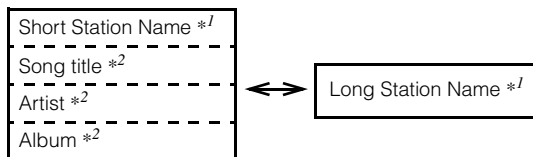

\*1 Displays Short Station Name / Long Station Name in the Station Information Service Data.

\*2 Displays Song title / Artist / Album in the main program Service Data.

## Other Useful Features

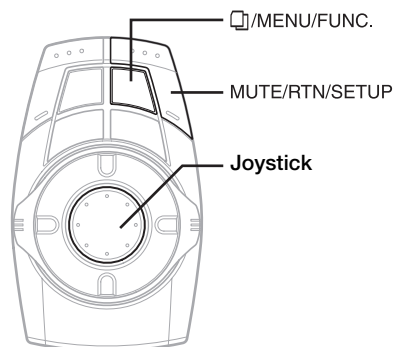

## Adjusting the Audio

The following steps 1 to 5 are common operations of each audio adjustment. Refer to each section for details.

- 1 Press and hold **MUTE/RTN/SETUP** for at least 2 seconds.  
The SETUP screen is displayed.
- 2 Press the **joystick up or down** to select **AUDIO MODE**, then press the **joystick right**.  
The AUDIO MODE screen is displayed.

*Display Example for Audio MODE Screen*



- 3 Press the **joystick up or down** to select the desired item.

Setting items: BALANCE / FADER / TREBLE / BASS / SUBW LEVEL / LOUDNESS / DEFEAT / GUIDE MIX LV\*

\* Setting can be made only when an external audio processor is connected.

- 4 Press the **joystick left or right** to adjust and set the desired item.
- 5 Press **MUTE/RTN/SETUP** to return to the previous screen. Press **MUTE/RTN/SETUP** repeatedly to return to the main source screen displayed before starting the setup operation.

## Adjusting the Balance

Adjust the sound volume of the left and right speakers.

Setting item: BALANCE  
Setting range: L15 to R15

## Adjusting the Fader

Adjust the volume of the front and rear speakers.

Setting item: FADER  
Setting range: F15 to R15

## Setting the Treble Control

You can change the Treble Frequency emphasis to create your own tonal preference.

- 1 Select **TREBLE** on the AUDIO MODE screen, then press the joystick right.
- 2 Press the joystick up or down to select the desired item, then press the joystick left or right to adjust and set the desired item.

### Setting the treble level

You can boost or cut treble frequencies.  
(The level of each audio source can be adjusted.)  
Setting item: LEVEL  
Setting level: -7 to +7

### Setting the treble center frequency

The displayed treble frequency is boosted.  
(Common to each audio source.)  
Setting item: FREQUENCY  
Setting range: 7.5kHz ↔ 10kHz ↔ 12.5kHz ↔ 15kHz

- Adjustment cannot be performed when an external audio processor is connected and DEFEAT is set to ON.

## Setting the Bass Control

You can change the Bass Frequency emphasis to create your own tonal preference.

- 1 Select **BASS** on the AUDIO MODE screen, then press the joystick right.
- 2 Press the joystick up or down to select the desired item, then press the joystick left or right to adjust and set the desired item.

### Setting the bass level

You can boost or cut bass frequencies.  
(The audio source level can be adjusted.)  
Setting item: LEVEL  
Setting level: -7 to +10

### Setting the slope

Select the frequency you want to set within the available range.  
(Common to each audio source.)  
Setting item: SLOPE  
Setting range: 0.50 ↔ 0.75 ↔ 1.00 ↔ 1.25

## Setting the bass center frequency

The displayed bass frequency is boosted.  
(Common to each audio source.)  
Setting item: FREQUENCY  
Setting range: 60Hz ↔ 80Hz ↔ 100Hz ↔ 120Hz

- Adjustment cannot be performed when an external audio processor is connected and DEFEAT is set to ON.

## Adjusting the Subwoofer Level

Adjust the subwoofer output.

Setting item: SUBW LEVEL  
Setting range: 0 to 15

- The level adjustment becomes available when ON is set in "Subwoofer On and Off" (page 16).

## Tuning Loudness ON or OFF

Loudness introduces a special low- and high-frequency emphasis at low listening levels. This compensates for the ear's decreased sensitivity to bass and treble sound.

Setting item: LOUDNESS  
Setting range: ON / OFF

- Adjustment cannot be performed when an external audio processor is connected and DEFEAT is set to ON.

## Tuning Defeat ON or OFF

By setting Defeat ON, previously adjusted settings of BASS and TREBLE will return to the factory defaults.

Setting item: DEFEAT  
Setting range: ON / OFF

## Adjusting Volume of GUIDE Voice

The volume level of the speaker input voice and the navigation interrupt voice output from the external audio processor is adjusted.

Setting item: GUIDE MIX LV  
\* Setting range: 0 to 15

- \* Make sure to adjust this setting to 15. Otherwise operation may not be correctly performed.
- Adjust the speaker input voice interruption level in "Adjusting the Speaker Input Voice Interruption Level" (page 14) and "Navigation Audio Interruption Volume Adjustment" (page 15).

## Rear Entertainment Function

The rear entertainment function independently routes different sources to the front and the rear inside a car. For example, while listening to the radio or other audio source in the front, DVD can be enjoyed in the rear with the optional rear monitor and headphones.

To connect the rear monitor, the optional expansion box VPE-S431 is required.

### 1 Press and hold **MUTE/RTN/SETUP** for at least 2 seconds.

The SETUP screen is displayed.

### 2 Press the joystick up or down to select **REAR SELECT**, then press the joystick right.

The REAR SELECT screen is displayed.

*Display Example for REAR SELECT screen*

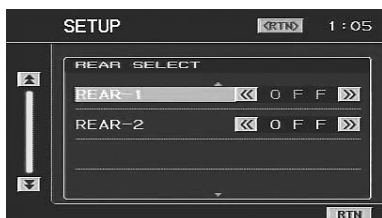

- This function cannot be used when MONITOR-1 or 2 is set to OFF in SYSTEM SETUP.

### 3 Press the joystick up or down to select the desired external monitor.

REAR-1: A rear external monitor can be connected to AUX OUT 1 of the optional expansion box (VPE-S431).

REAR-2: A rear external monitor can be connected to AUX OUT 2 of the optional expansion box (VPE-S431)

### 4 Press the joystick left or right to set the desired video source (external input).

### 5 Press **MUTE/RTN/SETUP** to return to the previous screen. Press **MUTE/RTN/SETUP** repeatedly to return to the main source screen displayed before starting the setup operation.

- To cancel the rear entertainment function, set to OFF.
- When the "Setting the AUX Mode" (page 15) is set to OFF, the auxiliary source is not displayed.
- VISUALIZER (VISUAL.) is not displayed when the setting of "Setting the VISUALIZER Mode Display" (page 16) is turned off.

## Switching the function of the remote sensor

For remote control operation, the remote sensor of the external device (monitor, etc.) can be switched, as you prefer.

### Switching the Remote Control Sensor

#### 1 In the SETUP screen mode, press the joystick up or down to select **SYSTEM SETUP**, then press the joystick right.

The SYSTEM SETUP screen is displayed.

#### 2 Press the joystick up or down to select **REMOTE SEL.**

### 3 Press the joystick left or right to select the monitor to be controlled by the remote control.

FRONT: Remote control operation can be performed when the Alpine monitor is connected using an RGB cable, and also when a monitor (other than Alpine) connected to a remote control sensor unit (optional) is connected.

REAR-1: The remote sensor of the external monitor connected to AUX OUT1 of the tuner box of this unit, or the optional expansion box (VPE-S431) is effective, and the remote control can operate only the source selected for the REAR SELECT screen.

REAR-2: The remote sensor of the external monitor connected to AUX OUT2 of the optional expansion box (VPE-S431) is effective, and the remote control can operate only the source selected for the REAR SELECT screen.

### 4 Press **MUTE/RTN/SETUP** to return to the previous screen. Press **MUTE/RTN/SETUP** repeatedly to return to the main source screen displayed before starting the setup operation.

- Select SETUP on the FUNCTION screen to recall the SETUP screen after pressing and holding **MENU/FUNC.** for at least 2 seconds.
- The sensor of the touch panel rear monitor has priority over the sensor of the remote control, if the rear monitor (connected to the Alpine touch panel rear monitor via the Monitor control lead) is touched, regardless of the remote control sensor switch setting. Note, however, that the sensor of the remote control that has been set takes priority if it has been 5 seconds since last touching the panel.

# Setup

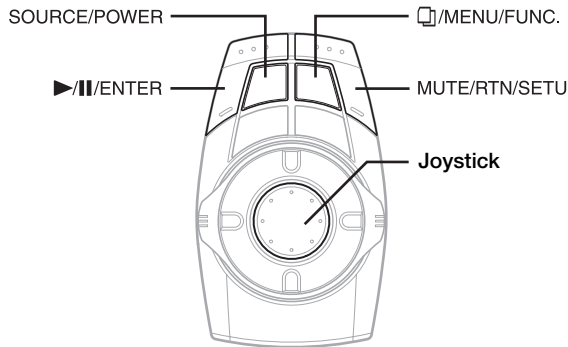

## GENERAL Setup

### General Setup Operation

#### To display the General mode screen:

To watch a video source, your vehicle must be parked with the ignition key in the ACC or ON position. To do this, follow the procedure below.

- 1 Bring your vehicle to a complete stop at a safe location. Engage the parking brake.
- 2 Keep pushing the foot brake and release the parking brake once then engage it again.
- 3 When the parking brake is engaged for the second time, release the foot brake.

- For automatic transmission vehicles, place the transmission lever in the Park position.

Now, the locking system for the General mode operation has been released. Engaging the parking brake can reactivate the General mode, as long as the car's ignition has not been turned off. It is not necessary to repeat the above procedure (1 through 3), of "To display the General mode screen." Each time the ignition is turned OFF, perform the procedure of "To display the General mode screen."

The following steps 1 to 5 are common operations to each "Setting item" of GENERAL Setup. Refer to each section for details.

#### 1 Press and hold **MUTE/RTN/SETUP** for at least 2 seconds.

The SETUP screen is displayed.

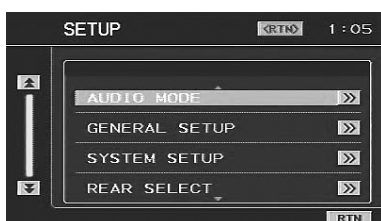

#### 2 Press the joystick up or down to select **GENERAL SETUP**, then press the joystick right.

The GENERAL SETUP screen is displayed.

#### Display Example for GENERAL SETUP Screen

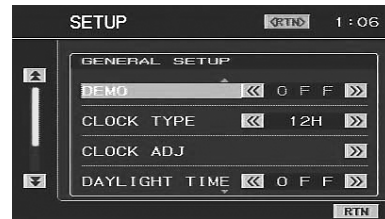

#### 3 Press the joystick up or down to select the desired item.

##### Setting items:

DEMO / CLOCK TYPE / CLOCK ADJ / DAYLIGHT TIME / BEEP / REACTOR / SCROLL AUTO

#### 4 Press the joystick left or right to adjust and set the desired item.

#### 5 Press **MUTE/RTN/SETUP** to return to the previous screen. Press **MUTE/RTN/SETUP** repeatedly to return to the main source screen displayed before starting the setup operation.

- Select **SETUP** on the **FUNCTION** screen to recall the **SETUP** screen after pressing and holding □/MENU/FUNC. for at least 2 seconds.
- Immediately after changing the settings of General Mode (While the system is writing data automatically) do not turn the ignition key (engine key) to OFF. Otherwise, the settings may not be changed.

## Demonstration Function

This unit is equipped with a demonstration function capable of showing basic operations of respective sources on the monitor display.

##### Setting item: DEMO

##### Setting content: OFF / ON

- ON: Turns on the demonstration mode to show the basic operations.
- OFF: Turns off the demonstration mode.

- The demonstration operation is automatically repeated until the function is turned off.

## Setting the Time Display

The time display type can be set.

##### Setting item: CLOCK TYPE

##### Setting content: OFF / 12H / 24H

- 12H: Clock indication is displayed for 12 hours.
- 24H: Clock indication is displayed for 24 hours.
- OFF: Clock indication is turned off.

## Setting the Time

**Setting item:** CLOCK ADJ

**Further setting items:** HOUR / MINUTE

**Setting content:** 1-12 (0-23)\* / 0-59

- HOUR: Adjust the hour.  
MINUTE: Adjust the minute.

\* The setting content differs depending on the selection in "Setting the Time Display" (page 12).

- Pressing and holding the joystick left or right will change the setting item continuously.

## Setting Daylight Saving Time

**Setting item:** DAYLIGHT TIME

**Setting content:** OFF / ON

- ON: Place the Summer Time mode ON. The time advances by one hour.  
OFF: Return to the ordinary time.

## Sound (Beep) Guide Function

**Setting item:** BEEP

**Setting content:** OFF / ON

- ON: Activate the Sound Guide mode.  
OFF: Deactivate the Sound Guide mode. The sound guide beep will not be produced when a button on the commander is pressed.

## Turning the Commander Vibration ON or OFF

You can turn the commander vibration ON or OFF during operation.

**Setting item:** REACTOR

**Setting content:** OFF / ON

- OFF: Turns off vibration during operation.  
ON: Turns on vibration during operation.

## Setting the Scroll

Scroll display is available if CD text, folder name, file name or tag information is entered.

**Setting item:** SCROLL AUTO

**Setting content:** OFF / ON

- ON: Turns on the AUTO scroll mode. Scroll display is repeated as long as the mode is turned on.  
OFF: Turns off the AUTO scroll mode.  
Scroll display is done once as a track is changed.

- Scroll display of the song, artist and album name is enabled when iPod is connected.
- Short/Long station name, song, artist and album name scrolling are displayed in HD Radio mode.

# SYSTEM Setup

## System Setup Operation

### To display the System mode screen:

To watch a video source, your vehicle must be parked with the ignition key in the ACC or ON position. To do this, follow the procedure below.

- Brake to bring your vehicle to a complete stop at a safe location. Engage the parking brake.
- Keep pushing the foot brake and release the parking brake once then engage it again.
- When the parking brake is engaged for the second time, release the foot brake.

- For automatic transmission vehicles, place the transmission lever in the Park position.

Now, the locking system for the System mode operation has been released. Engaging the parking brake can reactivate the System mode, as long as the car's ignition has not been turned off. It is not necessary to repeat the above procedure (1 through 3), of "To display the System mode screen."

Each time the ignition is turned OFF, perform the procedure of "To display the System mode screen."

The following steps 1 to 5 are common operations to each "Setting item" of SYSTEM Setup. Refer to each section for details.

- Press and hold **MUTE/RTN/SETUP** for at least **2 seconds**.

The SETUP screen is displayed.

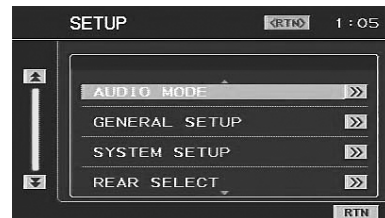

- Press the joystick up or down to select **SYSTEM SETUP**, then press the joystick right.

The SYSTEM SETUP screen is displayed.

Display Example for the SYSTEM SETUP Screen

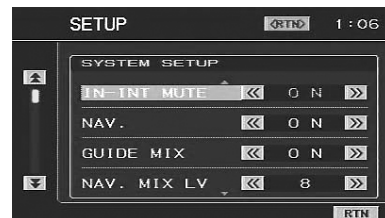

### 3 Press the joystick up or down to select the desired item.

#### Setting items:

IN-INT MUTE / NAV. / GUIDE MIX / NAV. MIX LV / FACT SYS SET / FACT SYS LV / FACT SYS DET / FACT SYS MIX / F.SYS MIX TP / F.SYS INT CH. / REMOTE SEL.\*<sup>1</sup> / AUX IN-1(2,3) / AUX IN-1(2,3) NAME / AUX IN-1(2,3) LEVEL / MONITOR-1 / MONITOR-2 / VISUALIZER / ILLUM COLOR / CMNDR LIGHT. / DIMMER / ADF / SCREEN ADJ / SUBW\*<sup>2</sup>

\*<sup>1</sup> Refer to "Rear Entertainment Function" on page 11.

\*<sup>2</sup> When an external audio processor is connected, the SUBW item is not displayed.

### 4 Press the joystick left or right to adjust and set the desired item.

### 5 Press MUTE/RTN/SETUP to return to the previous screen. Press MUTE/RTN/SETUP repeatedly to return to the main source screen displayed before starting the setup operation.

- Select SETUP on the FUNCTION screen to recall the SETUP screen after pressing and holding /MENU/FUNC. for at least 2 seconds.
- Immediately after changing the settings of System Mode (While the system is writing data automatically) do not turn the ignition key (engine key) to OFF. Otherwise, the settings may not be changed.

## Using the Speaker Input

The unit can interrupt the system (navigation or telephone) of the car. The audio can also be played back on the unit if the car system of the audio (CD, etc.) is selected as the source.

The unit makes the sound interruption according to the sound output level of the car system. If any of the following settings are not correctly made, sound may not interrupt, or loud sound may suddenly interrupt.

### Setting the Speaker Input Mode

The following explains how to install the system (navigation/telephone) in your car. While listening to the radio, you can have navigation voice guidance or a received telephone call interrupt automatically. You can also select the speaker input mode (FACTORY SYS) on the source selection screen.

#### Setting items: FACT SYS SET

#### Setting content: OFF / SOURCE / INT / BOTH

- SOURCE: The system (CD, etc.) of the car can be selected as a source.  
Navigation/telephone voice of the car is not interrupted.
- INT: Interrupts only the navigation/telephone voice of the car.
- BOTH: The system (CD, etc.) of the car can be selected as the source.  
Navigation/telephone voice of the car is interrupted.
- OFF: Operation and setting of the speaker input mode is not performed.

- If the car system (CD, etc.) is set to SOURCE and played back in a car with multi-channel speakers, sound such as treble, etc., may not be correctly output.
- Depending on the conditions of use, the INT or SOURCE setting is recommended.
- If INT is set, do not output CD audio from the car system.
- With BOTH set, if the source is set to other than FACTORY SYS, do not output CD audio, etc., from the car system.
- If OFF is set, speaker input mode settings cannot be made.

## Displaying the Speaker Input Volume Level

The volume level of the speaker input is displayed numerically. Adjustment can be made only on the system in your car (standard car audio, etc.), and cannot be made by this unit.

#### Setting items: FACT SYS LV

#### Setting content: 0 to 2 L / 3 to 15: OK / 16 to 18 H

- L: Volume level is LOW  
OK: Volume level is optimally adjusted  
H: Volume level is HIGH

Adjust the volume for optimum level.

- Set the volume as loud as possible, but before the onset of distortion (The volume level should not exceed 15). Even if OK is displayed, if any distortion is apparent, decrease the car audio's volume.
- Turn off the car audio's TREBLE, BASS settings.
- The volume level cannot be displayed when OFF is set in "Setting the Speaker Input Mode" (page 14).

## Setting the Navigation/Speaker Input Voice Interruption

With an Alpine navigation system connected to the VPA-B222, the voice guidance of the navigation system will be mixed with the radio play. Also, the setting of interruption of the speaker input voice can be adjusted.

#### Setting item: GUIDE MIX

#### Setting content: OFF / ON

- OFF: The navigation/speaker input interruption mode is turned off.  
ON: The navigation/speaker input interruption mode is on.

## Adjusting the Speaker Input's Interruption Detection Level

You can set the level for voice interruption.

#### Setting items: FACT SYS DET

#### Setting level: 1 to 15

When the setting level is low, the voice interrupts even if a low volume level is set on the system

- The setting can be made when INT or BOTH is set in "Setting the Speaker Input Mode" (page 14).
- Warning beeps such as for seat belts may also output from the speakers, depending to the car. Make sure that voice interruption sounds correctly in such a car.
- We recommend initially setting the level to 8. Set the voice interruption level to more than 8 if interruption is too frequent, or set it to less than 8 if interruption is not frequent enough.

## Adjusting the Speaker Input Voice Interruption Level

The output level of the speaker input interruption can be adjusted.

#### Setting items: FACT SYS MIX

#### Setting level: 0 to 15

- The setting can be made when INT or BOTH is set in "Setting the Speaker Input Mode" (page 14).
- Begin this setting after setting GUIDE MIX to ON and GUIDE MIX LV to 15, when an external audio processor is connected. For details, refer to "Setting the Navigation/Speaker Input Voice Interruption" (page 14) and "Adjusting Volume of GUIDE Voice" (page 10).



## Setting the Interrupt Type of the Speaker Input Voice

The following explanation is how to set the voice interrupt type of the speaker input. When the navigation voice guidance is made to interrupt, set to DEMAND, and the telephone voice is made to interrupt, set to MUTE, these are recommended.

**Setting items:** F.SYS MIX TYP

**Setting content:** FULL / DEMAND / MUTE

- FULL:** Regardless of the speaker interruption detection level, voice interruption and source sound are both active. If voice interruption cannot be heard clearly, adjust the source volume accordingly on the commander.
- DEMAND:** When speaker input interruption occurs, voice interruption may be too high or too low, adjust the source volume so voice interruption can be heard. If no speaker input interruption occurs for 5 seconds, source volume returns to the level you initially set. When speaker input interruption occurs again, source volume level automatically returns to the last one you set.
- MUTE:** To avoid voice interruption not being heard clearly, this setting mutes the current source sound whenever speaker input interruption occurs. In this setting, even when voice interruption cannot be heard clearly, you can still set the volume by the commander. When speaker input interruption occurs, the commander buttons blink. Press SOURCE/POWER to cancel voice interruption.
- The setting can be made when INT or BOTH is set in "Setting the Speaker Input Mode" (page 14).

## Setting the Channel of the Speaker Interruption Detection

The setting should be made according to the speaker output of the car system (navigation/telephone).

**Setting items:** F.SYS INT CH.

**Setting content:** L / R / BOTH

- L:** Outputs from the left speaker of the car system.  
**R:** Outputs from the right speaker of the car system.  
**BOTH:** Outputs from both speakers of the car system.
- Usually set to BOTH.
  - The setting can be made when INT or BOTH is set in "Setting the Speaker Input Mode" (page 14).
  - The speaker input interrupt voice is output from the right and left front speaker regardless of this setting.

## Connecting the Navigation

If an Alpine navigation system is connected, make the necessary settings in "Setting the Navigation/Speaker Input Voice Interruption" (page 14). Also make the following settings.

### Setting the Navigation Mode

When you connect optional navigation equipment, set to ON.

**Setting item:** NAV.

**Setting contents:** OFF / ON

- ON:** Navigation source is displayed.  
**OFF:** Navigation source is not displayed. The settings related to the navigation cannot be changed from this unit.

## Navigation Audio Interruption Volume Adjustment

With an Alpine navigation system connected to the VPA-B222, the voice guidance of the navigation system will be mixed with the DVD or CD playback sound.

You can adjust the volume level of the voice guidance.

**Setting item:** NAV. MIX LV

**Setting contents:** 0 to 15

- When NAV. is turned on, the setting can be made. Refer to "Setting the Navigation Mode" (page 15).

## Connecting an External Input Device (AUX)

If an external input device is connected, make the following settings.

### Setting the AUX Mode

**Setting item:** AUX IN-1, 2, 3

**Setting content:** OFF / ON

- OFF:** AUX source is not displayed.  
**ON:** AUX source is displayed.

- When OFF is selected, the settings related to AUX cannot be changed from this unit.
- AUX IN-3 is adjustable when the external expansion box (VPE-S431) is connected.
- OFF is not displayed when a DVD player or DVD changer is connected with the optional Ai-NET.
- When either DVD player or DVD changer is connected to AUX IN 1, DVD is displayed on the screen. When both of them are connected, DVD is displayed for AUX IN 1 and DVD CHANGER is displayed for AUX IN 2.

### Naming External Devices

When more than one external device is connected, you can name each (up to 3) as you like.

**Setting items:** NAME

**Setting contents:** AUX / VCR / GAME-1,2 / TV / EXTDVD\*

- The setting can be made when ON is set in "Setting the AUX Mode" (page 15).
- The selected source name is displayed instead of AUX source name. If selecting TV/EXT.DVD as the source, the screen will change to the function screen of that source.
- Only when an Alpine TV tuner is connected, can you operate the displayed function guide from this unit.
- If an Ai-NET compatible DVD player/DVD changer is connected, names are automatically set, however, they cannot be changed.
- \* "EXT.DVD" is displayed on the source selection screen when a DVD player is connected, and "DVD-1-3" is displayed on the source selection screen when the NAME setting is set to "EXTDVD" on more than one AUX (included when an external Ai-NET compatible DVD player is connected).

### Adjusting the External Input Audio Level

**Setting item:** LEVEL

**Setting content:** LOW / HIGH

- LOW:** Decreases the external input audio level  
**HIGH:** Increases the external input audio level

- The adjustment is available when ON is set in "Setting the AUX Mode" (page 15).

## Connecting the Rear Monitor

If the rear monitor is connected, make the following each setting

### Setting of the External Monitor Output

Set it to ON when you use the rear entertainment function (page 11).

**Setting items:** MONITOR-1, 2

**Setting contents:** OFF / ON

- ON: By setting the connected external monitor to ON, the remote control will be usable.
- OFF: When either MONITOR-1 or 2 is set to OFF, only one monitor can be set by the rear entertainment function. When both MONITOR-1 and 2 are set to OFF, the rear entertainment function cannot be used.

- This setting can be made if optional expansion box VPE-S431 is connected.

### Setting the VISUALIZER Mode Display

Note that this setting is enabled only when the optional expansion box (VPE-S431) is connected.

**Setting item:** VISUALIZER

**Setting contents:** MODE-1 - MODE-6 / SCAN / OFF

- MODE-1 to MODE-6 / OFF: Recalls the maker's setting mode on the expansion box (VPE-S431).
- SCAN: Displays the pattern of MODE-1 to MODE-6 repeatedly.

- VISUALIZER can be displayed in a rear monitor when mode is set to other than OFF. Set the source of the rear monitor to VISUAL to display VISUALIZER in the rear monitor. For the rear monitor's setting, refer to "Rear Entertainment Function" (page 11).

## Connecting a Subwoofer

When a subwoofer is connected, set to ON.

### Subwoofer On and Off

**Setting item:** SUBW

**Setting contents:** ON / OFF

- ON: Subwoofer output is on.
- OFF: Subwoofer output is off.

- When an external audio processor is connected, refer to "Setting the Speakers" (page 33) for setting.

## Setting the Commander

The color/brightness, etc., of buttons lighting on the commander supplied with the unit can be adjusted.

## Setting the Color of the Commander Button illumination

You can set the illumination color of the commander buttons.

**Setting items:** ILLUM COLOR

**Setting content:** BLUE / RED

- BLUE: When a source other than navigation is activated, illumination is blue. When the navigation is activated, illumination is red.
- RED: When a source other than navigation is activated, illumination is red. When navigation is activated, illumination is blue.

## Turning the Commander Button illumination on and off

You can select whether the commander button illumination remains lit or blinks when no operation is performed for 5 minutes.

**Setting items:** CMNDR LIGHT.

**Setting content:** ON / OFF

- ON: Commander button illumination blinks.
- OFF: Commander button illumination stays lit. (does not blink).

## Adjusting the Brightness of the Commander Button illumination

With AUTO set, when the headlights are turned on, the commander button illumination dims. During the night, if the commander button illumination is too bright, this setting is recommended.

**Setting items:** DIMMER

**Setting content:** OFF / ON / AUTO

- OFF: Brightness of the commander button illumination is maximum.
- ON: Brightness of the commander button illumination is decreased.
- AUTO: When the headlights are turned on, the commander button illumination dims.

## Setting the Others

### Setting the External Device Interrupt Mode

If an Alpine Versatile Link Terminal (KCA-410C) is connected to the VPA-B222, an Auxiliary Source will be allowed to interrupt the current audio source. For example, you can listen to a portable MP3 player through your car audio system even with a CD changer connected and playing. The CD changer will automatically mute when switched to the AUX Input. For further details on how to use the Alpine KCA-410C, see your authorized Alpine dealer.

**Setting item:** IN-INT MUTE

**Setting content:** OFF / ON

- OFF: Sound will be output in Interrupt mode.
- ON: Sound will not be output in Interrupt mode.

- The auxiliary device being connected must have an interrupt wire with a negative trigger for this function to operate automatically. Otherwise, a separate switch needs to be added to switch it manually.

## Adjusting the display position

Depending on the connected monitor, the display may move out of position. During touch panel operation, if the position between the display on the LCD and the display of the touch panel does not match, adjust the display position.

**Setting items:** SCREEN ADJ

**Setting content:** >>

**Adjustment if a monitor not compatible with touch panel operation is connected.**

The screen position within the display is adjustable. The position is controlled from the commander.

- 1 In the SCREEN ADJ mode, press the joystick right. The adjustment screen appears.
- 2 Press the joystick up, down, left or right to adjust the display position.
- 3 Press ►/II/ENTER. The adjustment is complete, and the display returns to the main source screen.

**Adjustment if a touch panel compatible monitor is connected.**

The screen and soft button positions are adjustable within the display. The position is controlled from the soft buttons.

- 1 Touch [ >>> ] of SCREEN ADJ.
- 2 Touch [▲], [▼], [◀] or [▶] to adjust the display position, and touch [ENT]. The TOUCH LOCATE screen is displayed.
- 3 Touch the center the ☒ mark displayed in the lower left of the screen. The screen changes to the adjustment screen.
- 4 Touch the center of the ☒ mark displayed in the upper right of the screen, then touch [ENT]. The adjustment is complete, and the display returns to the main source screen.

## Setting the Auxiliary Data Field Display

This display can be used only when the optional XM Satellite Radio Receiver is connected.

**Setting item:** ADF

**Setting content:** OFF/ON

- ON: The Auxiliary Data Field is displayed in the XM mode.  
OFF: The Auxiliary Data Field is not displayed.

# CD/MP3/WMA Operation (Optional)

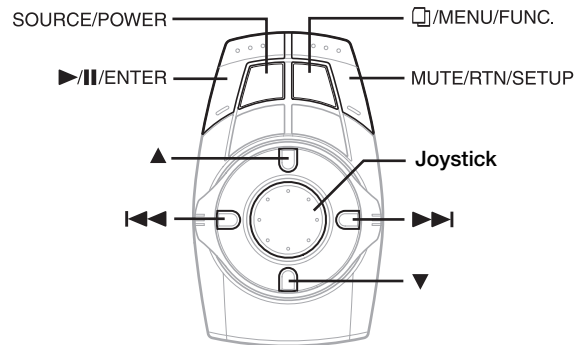

**Display example for MP3/WMA main screen**

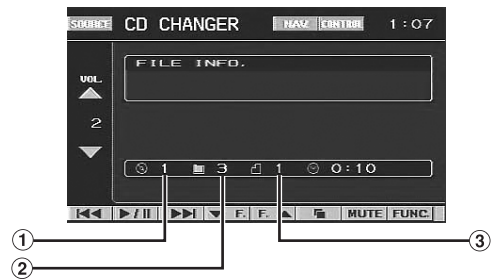

- ① Disc number display
- ② Folder number display
- ③ File number display

## Playing CD/MP3/WMA

- 1 Press **SOURCE/POWER**. The source selection screen is displayed.
- 2 Press the **joystick up or down** to select the CD/MP3/WMA mode (CD CHANGER, etc.), then press **►/II/ENTER**.
- 3 Press and hold **▲ or ▼** for at least 2 seconds to select a disc (when a changer is connected).
- 4 While playing back MP3/WMA. Press **▲ or ▼** to select the desired folder.

**5** Press **◀◀** or **▶▶** to select the desired track.

**Returning to the beginning of the current track:**

Press **◀◀**.

**Fast reverse:**

Press and hold **◀◀**.

**Advancing to the beginning of the next track:**

Press **▶▶**.

**Fast forward:**

Press and hold **▶▶**.

**6** To pause playback, press **▶/||/ENTER**.

Pressing **▶/||/ENTER** again will resume playback.

- CD playback information (track no., text etc.) will be displayed on the monitor during playback.
- MP3/WMA playback information (folder no., file no., tag information, etc.) will be displayed on the monitor during playback.
- "NO SUPPORT" is displayed when text information is not compatible with the VPA-B222.
- The DVD changer (optional) is controllable as well as the CD changer.

### Multi-Changer Selection

With the KCA-410C (Versatile Link Terminal), you can connect two changers.

**1** Press and hold **□/MENU/FUNC.** for at least **2 seconds**.

The FUNCTION screen is displayed.

**2** Press the **joystick up or down** to select **CHG SEL**. Then press **▶/||/ENTER** to select the next changer (connected CD changers only).

---

## Folder/File Search

---

You can display the names of folders/files and search for a folder/file to play.

**1** Press **□/MENU/FUNC.** during playback.

The Folder Name list is displayed.

**2** Press the **joystick up or down** to select the desired folder.

**3** Press **▶/||/ENTER** to play back the first file in the selected folder.

### To search for a file in the selected folder

- 1 After selecting the folder in step 2, press the joystick right to change to the file search mode of the selected folder.
- If there is a file name list in the folder, **≫** is displayed.
    - 2 Press the joystick up or down to select a file, then press **▶/||/ENTER**.

The selected file is played back.
  - Pressing **MUTE/RTN/SETUP** will return to the previous screen.
  - Folder/File Name search cannot be made during M.I.X. play.
  - "ROOT" is displayed for the root folder which does not have folder name.

---

## M.I.X. (Random Play)

---

**1** Press and hold **□/MENU/FUNC.** for at least **2 seconds**.

The FUNCTION screen is displayed.

**2** Press the **joystick up or down** to select **M.I.X.**.

**When M.I.X. ≫ is displayed (changer is connected)**

**3** Press the **joystick right**.

**4** Press the **joystick up or down** to select the **M.I.X. mode**, then press **▶/||/ENTER**.

**CD mode:**

M.I.X.: Track are played back in random sequence.

M.I.X. ALL: The tracks on all the CDs in the current magazine will be included in the random playback sequence.

OFF: M.I.X. mode off.

\* When a CD changer equipped with the All M.I.X. function is connected.

**MP3/WMA mode:**

M.I.X. FLD: Only files in a folder are played back in random sequence.

M.I.X.: All files in a disc are played back in random sequence, and playback shifts to the next disc.

OFF: M.I.X. mode off.

**When ▶ M.I.X. is displayed**

**3** Press **▶/||/ENTER**.

M.I.X. mode is changed.

**CD mode:**

M.I.X. → OFF → M.I.X.

**MP3/WMA mode:**

M.I.X. FLD → M.I.X. → OFF → M.I.X. FLD

---

## Repeat Play

---

**1** Press and hold **□/MENU/FUNC.** for at least **2 seconds**.

The FUNCTION screen is displayed.

**2** Press the **joystick up or down** to select **REPEAT**.

**When REPEAT ≫ is displayed (changer is connected)**

**3** Press the **joystick right**.

**4** Press the **joystick up or down** to select the **REPEAT mode** and press **▶/||/ENTER**.

**CD mode:**

RPT: Only a track is repeatedly played back.

RPT DISC: A disc is repeatedly played back.

OFF: Repeat mode off.

**MP3/WMA mode:**

- RPT: Only a file is repeatedly played back.
- RPT FLD: Only files in a folder are repeatedly played back.
- RPT DISC: A disc is repeatedly played back.
- OFF: Repeat mode off

**When ► REPEAT is displayed**

**3** Press ►/II/ENTER.

The repeat mode is changed.

**CD mode:**

RPT → OFF → RPT

**MP3/WMA mode:**

RPT → RPT FLD → OFF → RPT

# DVD/Video CD Operation (Optional)

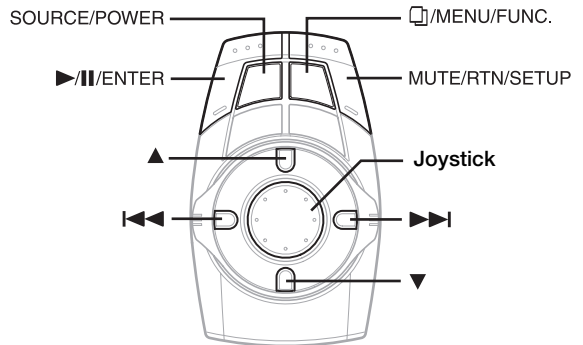

Display example for DVD main operation screen



## Playing DVD/Video CD

Basic operations of an Alpine DVD player/Changer can be done from the unit's supplied commander. Refer to the Owner's Manual of the connected DVD player/Changer.

When using an Alpine DVD Player/Changer, some of the commander functions may not be recognized. This varies from disc to disc. If the supplied VPA-B222 commander is not controlling a particular function of the DVD being played, please use the remote control that came with the DVD player.

**⚠ WARNING**

**It is dangerous (and illegal in many states) for the driver to watch the DVD/TV/Video while driving the vehicle. The driver may be distracted from looking ahead and an accident could occur.**

**Install the VPA-B222 correctly so that the driver cannot watch DVD/TV/Video unless the vehicle is stopped and the emergency brake is applied.**

**If the VPA-B222 is not installed correctly, the driver will be able to watch the DVD/TV/Video while driving the vehicle and may be distracted from looking ahead and cause an accident. The driver or other people could be severely injured.**

## To display the DVD mode screen

To watch a video source, your vehicle must be parked with the ignition key in the ACC or ON position. To do this, follow the procedure below.

- 1 Push the foot brake to bring your vehicle to a complete stop at a safe location. Engage the parking brake.
  - 2 Keep pushing the foot brake and release the parking brake once then engage it again.
  - 3 While the parking brake is being engaged the second time, release the foot brake.
- For automatic transmission vehicles, place the transmission lever in the Park position.

Now, the locking system for the DVD mode operation has been released. Engaging the parking brake can reactivate the DVD mode, as long as the car's ignition has not been turned off. It is not necessary to repeat the above procedure (1 through 3), of "To display the DVD mode screen."

Each time the ignition is turned OFF, perform the procedure of "To display the DVD mode screen."

- If you try to activate the auxiliary device while driving, the display will show the warning-**PICTURE OFF FOR YOUR SAFETY**.

### Caution

- **Not all functions will operate for every DVD. See the individual DVD's instructions for details on the features supported.**
- **If you try to perform an invalid operation (based on the type of disc being played), the following mark is displayed on the monitor screen: **

## 1 Press SOURCE/POWER.

The source selection screen is displayed.

## 2 Press the joystick up or down to select the DVD mode (EXT.DVD or DVD CHANGER, etc.), then press ►/II/ENTER.

Playback starts.

## If a menu screen appears

On DVDs and Video CDs with playback control (PBC), menu screens may appear automatically. The DVD menu can be controlled by the commander supplied with the unit. If this happens, perform the operation described below to start playback.



**Press the joystick up, down, left or right to select an item, then press and hold ►/II/ENTER for at least 2 seconds.**

- Press **MUTE/RTN/SETUP** to return to the previous screen.
- The Video CD menu screen cannot be controlled from the commander supplied with the unit.
- Depending on the disc, the menu screen may be recalled from the **FUNCTION** screen. Select **MENU** on the **FUNCTION** screen and press ►/II/ENTER to recall the menu, after displaying the **FUNCTION** screen by pressing and holding /MENU/FUNC. for at least 2 seconds.

## Playing Still Frames (Pausing)

- 1 During playback, press ►/II/ENTER.
- 2 Press ►/II/ENTER to resume playback.

## Finding the Beginnings of Chapters or Tracks

During playback, press  or .

The chapter/track switches each time the button is pressed, and playback of the selected chapter/track starts.

- : Press this to start playback from the beginning of the following chapter or track.
- ◄◄: Press this to start playback from the beginning of the current chapter or track.





- Some DVDs do not have chapters.

### Supplementary explanation

"Chapters" are divisions of movies or musical selections on DVDs.

"Tracks" are divisions of movies or musical selections on video and music CDs.

## Fast-forwarding/Fast-reversing

- 1 During playback, press and hold  (fast-reverse) or  (fast-forward).
- 2 Release  or  to return to normal playback.

## Displaying the Top Menu Screen (DVD only)

With a DVD having two or more titles, a top menu screen will appear.

**Press  $\square$ /MENU/FUNC. on the DVD mode main screen.**  
The menu screen appears.

- To perform necessary operations, see "If a menu screen appears" on page 20.

## Changing Discs (only when DVD changer is connected)

**Press and hold  $\blacktriangle$  or  $\blacktriangledown$  for at least 2 seconds.**

The selected disc is played back.

- Select **DISC SELECT** on the **FUNCTION** screen and press  $\blacktriangleright$ /II/ENTER to change discs, after pressing and holding  $\square$ /MENU/FUNC. for at least 2 seconds.

## Stopping Playback (PRE STOP)

Select the **PRE STOP** during playback to stop playback. That position is stored in the memory.

**1 During playback, press and hold  $\square$ /MENU/FUNC. for at least 2 seconds.**

The **FUNCTION** screen is displayed.

**2 Press the joystick up or down to select **STOP/PRE STOP**, then press  $\blacktriangleright$ /II/ENTER.**

"**PRE STOP**" is displayed.

**3 During PRE STOP mode, press  $\blacktriangleright$ /II/ENTER.**

Playback starts from the position at which it was stopped.

- For some discs, the position at which playback was stopped may not be accurate.
- When a DVD player/changer is connected with Ai-NET, **STOP/PRE STOP** is not displayed on the **FUNCTION** screen in the video CD mode.

## Stopping Playback

**1 During the PRE STOP mode, press and hold  $\square$ /MENU/FUNC. for at least 2 seconds.**

The **FUNCTION** screen is displayed.

**2 Press the joystick up or down to select **STOP/PRE STOP**, then press  $\blacktriangleright$ /II/ENTER.**

"**STOP**" is displayed, and playback stops.

- Playback starts from the beginning when  $\blacktriangleright$ /II/ENTER is pressed while playback is stopped.
- When a DVD player/changer is connected with Ai-NET, **STOP/PRE STOP** is not displayed on the **FUNCTION** screen in the video CD mode.

## Chapter/Track/Title Repeat Playback

Use this function to play the disc's titles, chapters or tracks repeatedly.

**1 Press and hold  $\square$ /MENU/FUNC. for at least 2 seconds.**  
The **FUNCTION** screen is displayed.

**2 Press the joystick up or down to select **REPEAT**, then press  $\blacktriangleright$ /II/ENTER.**

The screen changes to the repeat mode in the following step.

### DVD

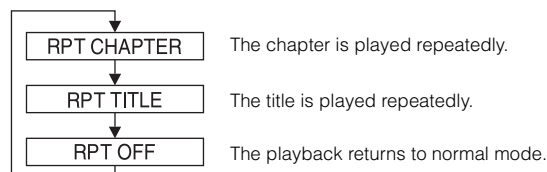

### Video CD

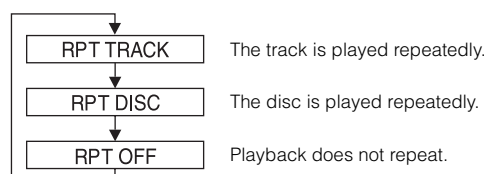

- Display may vary depending on the connected devices.
- The track/disc repeat modes cannot be used on video CDs with playback control (PBC). These modes can be carried out after turning PBC off.
- For some discs it is not possible to switch the repeat mode.
- The repeat mode may not be switched, depending on the connected product.

## Switching the Audio Tracks

DVDs can have up to 8 different audio tracks. These alternate tracks can be switched during playback.

**1 Press and hold  $\square$ /MENU/FUNC. for at least 2 seconds.**

The **FUNCTION** screen is displayed.

**2 Press the joystick up or down to select **AUDIO**, then press  $\blacktriangleright$ /II/ENTER.**

The sound switches between the alternate audio tracks recorded on the disc.

- The alternate track selected becomes the default setting every time the power is turned on or the disc is replaced. If the disc does not include that track, the disc's default language is selected instead.
- Not all discs will allow changing the alternate audio tracks during playback. In these cases, select audio tracks from the DVDs menu.
- There may be a delay before the selected alternate track begins to play.

## Video CDs with multiplex audio

- 1 Press and hold /MENU/FUNC. for at least 2 seconds.**

The FUNCTION screen is displayed.

- 2 Press the joystick up or down to select **AUDIO**, then press /II/ENTER.**

The left and right channels will be output as shown in the figure below.

<Monitor display>

AUDIO L/R → AUDIO L/L → AUDIO R/R → AUDIO L/R

- *If a DVD player/DVD changer with Ai-NET is connected, AUDIO is not displayed on the video CD function screen.*

---

## Switching the Subtitles (Subtitle Language) (DVD only)

---

With DVDs on which multiple subtitle languages are recorded, the subtitle language can be switched during playback; moreover, subtitles can be hidden.

- 1 Press and hold /MENU/FUNC. for at least 2 seconds.**

The FUNCTION screen is displayed.

- 2 Press the joystick up or down to select **SUB TITLE**, then press /II/ENTER.**

The subtitle language stored in the disc is changed, then turns off.

- *There may be a delay before the selected subtitle appears.*
- *Not all discs will allow changing the subtitles during playback. In these cases, select subtitles from the DVDs menu.*
- *The subtitle language selected becomes the default setting every time the power is turned on or the disc is replaced. If the disc does not include that language, the disc's default language is selected instead. However, the subtitle language may differ depending on the disc.*
- *For some discs, the subtitles will be displayed even when this is set to off. However, the subtitle language may differ depending on the disc.*

---

## Switching the Angle (DVD only)

---

On DVDs in which scenes have been filmed from multiple angles, the angle can be switched during playback.

- 1 Press and hold /MENU/FUNC. for at least 2 seconds.**

The FUNCTION screen is displayed.

- 2 Press the joystick up or down to select **ANGLE**, then press /II/ENTER.**

The angle switches between the angles recorded on the disc.

- *Some time may be required for the angle to change.*
- *Depending on the disc, the angle may switch in one of two ways.*
  - *Seamless: The angle switches smoothly.*
  - *Non-seamless: When the angle is switched, a still picture is displayed first, after which the angle switches.*

## Switching from the disc menu

For some discs, the audio language, angle and subtitles can be switched from the disc menu.

- 1 Press and hold /MENU/FUNC. for at least 2 seconds.**

The FUNCTION screen is displayed.

- 2 Press the joystick up or down to select **MENU**, then press /II/ENTER.**

- 3 Select an item to confirm it.**

See "If a menu screen appears" on page 20.



# SAT Radio Receiver (Optional)

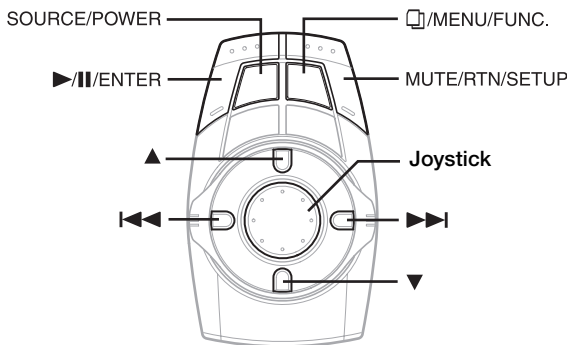

## SAT Receiver: XM or SIRIUS Receiver

When an optional XM or SIRIUS Receiver Box is connected via the Ai-NET bus, the following operations may be performed. However, the XM Receiver and SIRIUS Receiver cannot be connected at the same time.

## Receiving Channels with the SAT Receiver

### About SAT Radio

Satellite Radio\* is the next generation of audio entertainment, with over to 100 digital channels. For a small monthly fee, subscribers can hear crystal-clear music, sports, news and talk, coast-to-coast via satellite. For more information, visit XM's website at [www.xmradio.com](http://www.xmradio.com), and SIRIUS' website at [www.sirius.com](http://www.sirius.com).

To receive SAT Radio, the separately sold XMDirect™ or SIRIUS Satellite Radio Tuner and an appropriate Ai-NET Interface Adapter will be required. For details, consult you nearest Alpine dealer.

\* XM and its corresponding logos are trademarks of XM Satellite Radio Inc.

\* SIRIUS and its corresponding logos are trademarks of SIRIUS Satellite Radio Inc.

• The SAT Receiver controls on the VPA-B222 are operative only when a SAT Receiver is connected.

- 1 Press SOURCE/POWER.**  
The source selection screen is displayed.
- 2 Press the joystick up or down to select the SAT Radio mode (XM or SIRIUS).**
- 3 Press and hold ▲ for at least 2 seconds to select between one of the three SAT Radio Preset Bands.**  
Each press changes the band:

### XM radio:

XM-1 → XM-2 → XM-3 → XM-1

### SIRIUS radio:

SIRIUS-1 → SIRIUS-2 → SIRIUS-3 → SIRIUS-1

- 4 Press ►/||/ENTER to select the channel tuning.**  
Each time it is pressed, the tuning mode is changed.  
channel number tuning ↔ channel name tuning
  - 5 Press ◀◀ or ▶▶ to select the desired channel.**  
Holding down ◀◀ or ▶▶ will change channels continuously.
- When using the optional remote control (RUE-4190, etc.), an SAT Radio Channel can be directly called up with the numeric keypad of the remote control.
    - 1 While in XM or SIRIUS Radio mode, enter the Channel number you want to call up with the numeric keypad on the remote control.
    - 2 Press ENTER on the remote control within 5 seconds to receive the Channel.  
If the channel number is 3 digits, the Channel is automatically received after the channel number is input.

## Tuning in to Categorized Programs

You can listen to programs categorized to the same group one after another.

- 1 In the XM or SIRIUS mode, press and hold ►/||/ENTER for at least 2 seconds to select CATEGORY mode.**  
The CATEGORY indicator lights up.
- 2 Press ◀◀ or ▶▶ to select the desired channel in the category.**  
Holding down ◀◀ or ▶▶ will change channel continuously.
- 3 To cancel the CATEGORY mode, press and hold ►/||/ENTER for at least 2 seconds.**

## Changing the Display

Text information, such as the channel name, artist name/feature, and song/program title, is available with each XM or SIRIUS channel. The unit can display this text information as explained below.

- 1 Press and hold □/MENU/FUNC. for at least 2 seconds.**  
The FUNCTION screen is displayed.
- 2 Press the joystick up or down to select INFO., then press ►/||/ENTER.**

Each time you perform the above operations, the display changes as shown below.

### XM Radio:

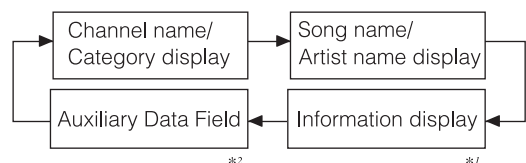

### SIRIUS Radio:

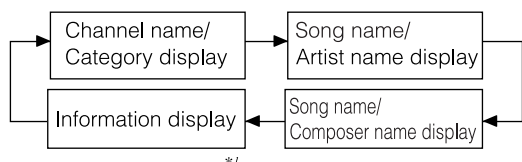

\*1 Channel name, category, song name, etc., are displayed in one screen.

\*2 XM mode only: The information display appears when ON is set in "Setting the Auxiliary Data Field Display" (page 17).

## Checking the SAT Radio ID Number

A unique Radio ID number is required to subscribe to SAT Radio programming. Each third party XM or SIRIUS radio comes with this number.

### XM Radio:

This number is an 8 character alphanumeric number. It is printed on a label found on the SAT Receiver.

### SIRIUS Radio:

This number is a 12 character alphanumeric number. It is printed on a label found on the SAT Receiver.

It can also be displayed on the screen of the VPA-B222 in the following way.

- 1 Press **▶/II/ENTER** to select the channel number tuning mode.
- 2 While receiving a SAT Radio band, press **◀◀** or **▶▶** to select channel "0" for XM, or to select channel "255" for SIRIUS.
- 3 The unit displays the ID number.
- 4 To cancel the ID number display, change the channel.

- You cannot use "O," "S," "I," or "F" for the ID Number. (XM radio Receiver only)
- You can check the ID number printed on a label on your third party, SAT Radio Receiver package.

## Storing Channel Presets

- 1 Press and hold **□/MENU/FUNC.** for at least 2 seconds after selecting a desired band. The FUNCTION screen is displayed.
- 2 Press the **joystick up or down** to select **PRESET MEMORY**, then press the **joystick right**.
- 3 Press the **joystick up or down** to select any one of the preset numbers **PRESET1** through **PRESET6**, then press **▶/II/ENTER**. The selected station is stored.
- 4 Repeat the procedure to store up to 5 other channels onto the same band. To use this procedure for other bands, simply select the desired band and repeat the procedure. A total of 18 channels can be stored in the preset memory (6 channels for each band; XM-1, XM-2 and XM-3 or SIRIUS-1, SIRIUS-2 and SIRIUS-3).

- If you store a channel in a preset already being used, the current channel will be replaced with the new one.

## Receiving Stored Channels

- 1 Press and hold **▲** for at least 2 seconds repeatedly until the desired band is displayed.
  - 2 Press and hold **□/MENU/FUNC.** for at least 2 seconds. The FUNCTION screen is displayed.
  - 3 Press the **joystick up or down** to select **PRESET CALL**, then press the **joystick right**.
  - 4 Press the **joystick up or down** to select any one of the preset numbers **PRESET1** through **PRESET6**, then press **▶/II/ENTER**. The selected station is received.
- During reception, you can change the station by pressing **▲** or **▼**.

## Category/Channel Search Function

You can search for programs by Category or Channel name.

- 1 Press **□/MENU/FUNC.**  
The Category Search screen is displayed.
- 2 Press the **joystick up** or **down** to select your desired category.

### To receive the category directly

- 1 Press **▶/II/ENTER.**  
The first channel of the selected category is tuned.

### To search for a channel in the category

- 1 Press the **joystick right** to change to the channel search mode of the selected category .
- 2 Press the **joystick up** or **down** to select a channel, then press **▶/II/ENTER.**  
The selected channel is received.

## Storing Weather or Traffic information from SAT Radio

- 1 While receiving weather or Traffic information in the SAT Radio mode, press and hold **□/MENU/FUNC.** for at least 2 seconds.  
The FUNCTION screen is displayed.
- 2 Press the **joystick up** or **down** to select **WEATHER MEMORY**, then press **▶/II/ENTER.**  
The received weather or traffic channel is stored.

## Receiving Weather or Traffic Information from SAT Radio

- 1 In the SAT Radio mode, press and hold **□/MENU/FUNC.** for at least 2 seconds.  
The FUNCTION screen is displayed.
  - 2 Press the **joystick up** or **down** to select **WEATHER CALL**, then press **▶/II/ENTER.**  
The weather or traffic channel is recalled.
  - 3 Press **MUTE/RTN/SETUP** to return to normal mode.
- When activated in a mode other than SAT Radio, the stored weather or traffic channel can be received.

## iPod® (Optional)

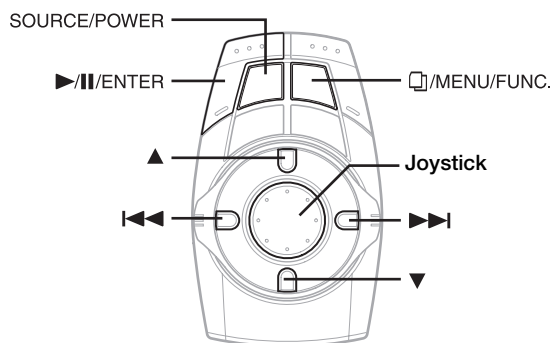

An iPod® can be connected to the VPA-B222 by using the proprietary ALPINE FULL SPEED™ Connection Cable (KCE-422i). When the VPA-B222 is connected by using the cable, the controls on the iPod are not functional.

### About iPod usable with this unit

The unit can be used with third generation and above iPod, iPod photo, iPod minis or iPod nano. iPod Shuffle cannot be used, however.

- Touch wheel or scroll wheel type iPods without the dock connector cannot be connected to the unit.
- The unit can be used with the following iPod versions. Correct function of earlier versions cannot be guaranteed.  
Third generation iPod: Ver. 2.3  
Fourth generation iPod: Ver. 3.0.2  
iPod photo: Ver. 1.1  
iPod mini: Ver. 1.3  
iPod nano: Ver. 1.0
- The unit cannot be used with the software versions earlier than 2005-02-22. For details about "iPod Software Update," refer to the iPod Instruction Manual.

## Playback

- 1 Press **SOURCE/POWER.**  
The source selection screen is displayed.
- 2 Press the **joystick up** or **down** to select iPod, then press **▶/II/ENTER.**
- 3 Press **◀◀** or **▶▶** to select the desired song.  
**Return to the beginning of the current song:**  
Press **◀◀**.  
**Fast reverse:**  
Press and hold **◀◀**.  
**Advance to the beginning of the next song:**  
Press **▶▶**.  
**Fast forward:**  
Press and hold **▶▶**.
- 4 To pause playback, press **▶/II/ENTER.** Pressing **▶/II/ENTER** again will resume playback.

- If a song is playing on the iPod when it is connected to the VPA-B222, it will continue playing after the connection.
- If the artist, album or song name, created in iTunes, has too many characters, songs may not be played back when connected to the adapter. Therefore, a maximum of 250 characters is recommended. The maximum number of characters for the head unit is 64 (64 byte).
- Some characters may not be correctly displayed.
- "NO SUPPORT" is displayed when text information is not compatible with the VPA-B222.

## Searching for a desired Song

An iPod can contain hundreds to thousands of songs. By keeping these songs organized in smaller playlists, the VPA-B222 has the ability to ease song searches.

- During shuffle (M.I.X.) playback, this operation is not possible.

### Searching by Playlist

- 1 Press **□/MENU/FUNC.**.  
The search mode is activated, and the search list screen appears.
- 2 Press the **joystick up or down to select PLAYLIST SEARCH**, then press the **joystick right**.
- 3 Press the **joystick up or down to select the playlist**.

#### To play back the playlist directly

- 1 Press **▶/||/ENTER**.  
The selected playlist is played back repeatedly.

#### To search for a song in the playlist

- 1 Press the **joystick right** to change to the song search mode of the selected playlist.
- 2 Press the **joystick up or down** to select a song, then press **▶/||/ENTER**.  
The selected song is played back.

### Searching by artist name

- 1 Press **□/MENU/FUNC.**.  
The search mode is activated, and the search list screen appears.
- 2 Press the **joystick up or down to select ARTIST SEARCH**, then press the **joystick right**.
- 3 Press the **joystick up or down to select the artist to be played back**.

#### To play back the artist directly

- 1 Press **▶/||/ENTER**.  
Songs by the selected artist are played back.
- Selecting **ALL** and pressing **▶/||/ENTER** plays back all songs from the beginning.
  - Selecting **ALL** and pressing the **joystick right** will change to the **ALBUM** search screen.

#### To search for the album of an artist

- 1 Press the **joystick right** to change to the album search mode of the selected artist.
  - 2\*<sup>1</sup> Press the **joystick up or down** to select the album to be played back.
  - 3 Press **▶/||/ENTER** to play back all songs of the selected album.  
Songs in the selected album are played back.
- Selecting **ALL** and pressing **▶/||/ENTER** will play back the first song of the selected artist.
  - Selecting **ALL** and pressing the **joystick right** will change to the **SONG** search screen of the selected artist

#### To search for a song in the album of an artist

- 1 After selecting the album in step 2\*<sup>1</sup>, press the **joystick right** to change to the song search mode of the selected album.
- 2 Press the **joystick up or down** to select a song, then press **▶/||/ENTER**.  
The selected song is played back.

### Searching by album name

- 1 Press **□/MENU/FUNC.**.  
The search mode is activated, and the search list screen appears.
- 2 Press the **joystick up or down to select ALBUM SEARCH**, then press the **joystick right**.
- 3 Press the **joystick up or down to select the album to be played back**.

### To play back the album directly

- 1 Press ►/||/ENTER.  
Songs in the selected album are played back.
- *Selecting ALL and pressing ►/||/ENTER plays back all songs from the beginning.*
  - *Selecting ALL and pressing the joystick right will change to the SONG search screen.*

### To search for a song in an album

- 1 Press the joystick right to change to the song search mode of the selected album.
- 2 Press the joystick up or down to select a song, then press ►/||/ENTER.  
The selected song is played back.

## Searching by Song Name

- 1 Press □/MENU/FUNC..  
The search mode is activated, and the search list screen appears.
- 2 Press the joystick up or down to select **SONG SEARCH**, then press the joystick right.
- 3 Press the joystick up or down to select a song, then press ►/||/ENTER.  
The selected song is played back.

## Select Playlist/Artist/Album

Playlist/Artist/Album can be easily changed.

For example, if you listen to a song from a selected album, the album can be changed.

- 1 Press ▲ or ▼ to select the desired **Playlist/Artist/Album**.
- *If search selection mode is not activated, only SONG is searched, this operation is not possible.*
  - *If an album is selected from an artist search, the album can be searched.*
  - *During shuffle (M.I.X.) playback, this operation is not possible.*

## Random Play Shuffle (M.I.X.)

The Shuffle function of the iPod is displayed as M.I.X. on the VPA-B222.

- 1 Press and hold □/MENU/FUNC. for at least 2 seconds.  
The FUNCTION screen is displayed.
- 2 Press the joystick up or down to select **M.I.X.**, then press the joystick right.

- 3 Press the joystick up or down to select the **M.I.X.** mode, then press ►/||/ENTER.

### **M.I.X. ALBUM:**

Album shuffle playback plays back all songs in order, then randomly selects the next album. All songs of that album are played back in order, and so on. Any one album is played just once.

### **M.I.X. SONGS:**

Song shuffle randomly plays back certain selected songs. Any one song plays back just once until all songs have been played back.

### **M.I.X. ALL:**

Shuffle ALL plays all songs in the iPod randomly. Any one song does not play back again until all songs have been played back.

### **OFF:**

M.I.X. mode is off.

- 4 To cancel M.I.X. play, select **OFF** in step 3, and press ►/||/ENTER.

- *For details of the search mode, refer to "Searching for a desired Song" (page 26).*
- *If a song is selected in the album search mode before selecting Shuffle (M.I.X.), the songs will not play back randomly even when Shuffle album is selected.*
- *If Shuffle ALL is selected, the selected ones which played back in the search mode are canceled.*

## Repeat Play

Only Repeat One is available for the iPod.

Repeat One: A single song is repeatedly played back.

- 1 Press and hold □/MENU/FUNC. for at least 2 seconds.  
The FUNCTION screen is displayed.
  - 2 Press the joystick up or down to select **REPEAT**, then press the joystick right.
  - 3 Press the joystick up or down to select **RPT**, then press ►/||/ENTER.  
The track is played back repeatedly.
  - 4 To cancel repeat play, select **OFF** in step 3, and press ►/||/ENTER.
- *During repeat playback, no other songs are selectable by pressing ◀◀ or ▶▶.*
  - *The repeat mode is canceled when iPod or iPod mini is removed or the ignition key is turned off.*

# Navigation System (Optional)

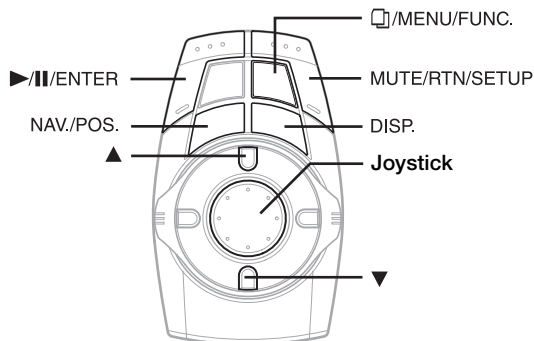

Basic Alpine navigation control can be performed by the commander supplied with the unit. Refer to the Owner's Manual of the navigation.

- If a navigation system that is not controlled by the remote control, but touch-panel operation only is connected, operations cannot be performed by the commander.

## Displaying the Navigation Screen

When an Alpine navigation system is connected, the navigation screen can easily be displayed.

- 1 Press **DISP.**  
The Navigation screen is displayed.
- 2 To cancel the screen, press **DISP.** again.

## Changing the Navigation operation mode

When an Alpine navigation system is connected, the navigation screen can easily be displayed, and some operations can be performed.

- 1 Press **NAV./POS.**  
The navigation screen is displayed, and the navigation mode becomes active.
  - 2 Press **DISP.** to cancel the operation mode, and return to the main source screen before the operation was performed.  
When **DISP.** is pressed and held for at least 2 seconds, the operation mode is canceled, the navigation screen display remains, and the sound returns to the selected source before the operation was performed.
- If the navigation mode is selected on the source selection screen, the navigation mode is not canceled even if **DISP.** is pressed.
  - The color of the commander buttons illumination changes in the navigation mode. Refer to "Setting the Color of the Commander Button Illumination" (page 16).

## Map Screen Function

### Displaying the Current Position

- 1 Press **NAV./POS.** while displaying the map screen.  
The current position screen is displayed.

### Scrolling the Map

- 1 Press the **joystick**.  
The map scrolls in the direction the joystick is pressed.

### Changing the Map Scale

- 1 Press **▲** or **▼**.  
Each press of the button changes the map scale. Pressing and holding changes the scale continuously.

## Menu Screen Function

- 1 Press **□/MENU/FUNC.** in the Navigation mode.  
The Navigation Menu screen is displayed.
  - 2 Press the **joystick** up, down, left or right to select the desired item.
  - 3 Press **▶/II/ENTER.**
- Press **MUTE/RTN/SETUP** to return to the previous screen.

# TV Operation (Optional)

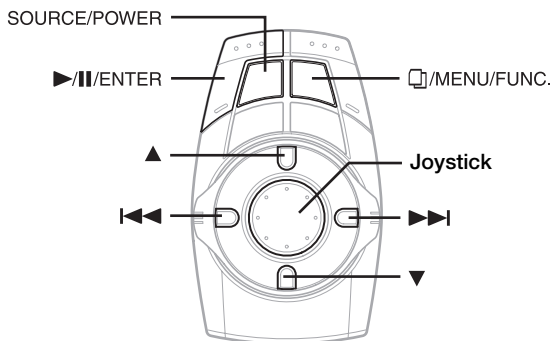

When connected to an Alpine TV unit (sold separately), you can use the commander supplied with the VPA-B222 to operate the TV. Set the AUX NAME to TV. Refer to "Naming External Devices" page 15.

- When the optional expansion box (VPE-S431) is connected, connect TV to AUX IN-2, 3.
- Be sure to connect this unit or VPE-S431 remote control output lead to the TV unit's remote control input lead.
- For details, refer to the owner's manual of the TV unit.

## Operating TV Unit

### WARNING

It is dangerous (and illegal in many states) for the driver to watch the TV while driving the vehicle. The driver may be distracted from looking ahead and an accident could occur.

Install the VPA-B222 correctly so that the driver cannot watch TV unless the vehicle is stopped and the emergency brake is applied.

If the VPA-B222 is not installed correctly, the driver will be able to watch the TV while driving the vehicle and may be distracted from looking ahead and cause an accident. The driver or other people could be severely injured.

### To activate your TV unit:

To watch a video source, your vehicle must be parked with the ignition key in the ACC or ON position. To do this, follow the procedure below.

- 1 Bring your vehicle to a complete stop at a safe location. Engage the parking brake.
- 2 Keep pushing the foot brake and release the parking brake once then engage it again.
- 3 When the parking brake is engaged for the second time, release the foot brake.

- For automatic transmission vehicles, place the transmission lever in the Park position.

Now, the locking system for the TV mode operation has been released. Engaging the parking brake can reactivate the TV mode, as long as the car's ignition has not been turned off. It is not necessary to repeat the above procedure (1 through 3), of "To activate your TV unit."

Each time the ignition is turned OFF, perform the procedure of "To activate your TV unit."

- If you try to activate the TV unit while driving, the display will show the warning-PICTURE OFF FOR YOUR SAFETY.

- 1 **Press SOURCE/POWER.**  
The source selection screen is displayed.
- 2 **Press the joystick up or down to select TV, then press ►/II/ENTER.**
- 3 **Press and hold ▲ for at least 2 seconds to select BAND.**
- 4 **Press ►/II/ENTER to switch the manual tuning mode.**  
Manual tune (Auto seek tune) ↔ Preset number tune
- 5 **Press ◀◀ or ▶▶ to change the channel up or down one by one. (manual mode)**  
The channel is searched and received automatically by pressing and holding. (Auto seek mode)

## Automatic Memory of Channel Presets

- 1 **Press and hold ►/II/ENTER for at least 2 seconds.**  
The auto preset operation starts.  
After the completion, memorized channel number list displays and the first memorized station is automatically received.
- 2 **To receive a memorized station, press ►/II/ENTER to switch the preset number tuning mode.**  
Manual tune (Auto seek tune) ↔ Preset number tune
- 3 **Press ◀◀ or ▶▶ to select a preset number.**

## Switching Audio

- 1 **Press and hold ◻/MENU/FUNC. for at least 2 seconds.**  
The FUNCTION screen is displayed.
- 2 **Press the joystick up or down to select AUDIO, then press ►/II/ENTER.**  
The audio mode is changed.

# Auxiliary Device (Optional)

## Operating Auxiliary Devices (Optional)

To operate devices connected to the AUX terminals of VPA-B222, follow the procedure described below.



### WARNING

**It is dangerous (and illegal in many states) for the driver to watch the TV/Video while driving the vehicle. The driver may be distracted from looking ahead and an accident could occur.**

**Install the VPA-B222 correctly so that the driver cannot watch TV/Video unless the vehicle is stopped and the emergency brake is applied.**

**If the VPA-B222 is not installed correctly, the driver will be able to watch the TV/Video while driving the vehicle and may be distracted from looking ahead and cause an accident. The driver or other people could be severely injured.**

### To activate your auxiliary devices:

To watch a video source, your vehicle must be parked with the ignition key in the ACC or ON position. To do this, follow the procedure below.

- 1 Bring your vehicle to a complete stop at a safe location. Engage the parking brake.
- 2 Keep pushing the foot brake and release the parking brake once then engage it again.
- 3 When the parking brake is engaged for the second time, release the foot brake.

- *For automatic transmission vehicles, place the transmission lever in the Park position.*

Now, the locking system for the AUX mode operation has been released. Engaging the parking brake can reactivate the AUX mode, as long as the car's ignition has not been turned off. It is not necessary to repeat the above procedure (1 through 3), of "To activate your auxiliary devices."

Each time the ignition is turned OFF, perform the procedure of "To activate your auxiliary devices."

- *If you try to activate an auxiliary device while driving, the display will show the warning-PICTURE OFF FOR YOUR SAFETY.*

### 1 Press SOURCE/POWER.

The source selection screen is displayed.

### 2 Press the joystick up or down to select the AUX mode, then press ►/II/ENTER.

The external input screen is displayed.

- *AUX-1 to AUX are displayed if AUX IN set to ON in "Setting the AUX mode" (page 15), or the name which is given as the source name in "Naming External Devices" on page 15 is displayed.*
- *AUX-3 is displayed when the optional expansion box (VPE-S431) is connected.*
- *When the Versatile Link Terminal (KCA-410C) is connected, external input to KCA-410C is unavailable. However, when IN-INT MUTE is set to off, the sound of a device connected to the external input of KCA-410C can be interrupted. (See "Setting the External Device Interrupt Mode" page 16.)*



# Factory System

## Operating Factory System (Speaker Input mode)

The car's system (standard CD player, etc.) can be selected as a source.

- 1 Press SOURCE/POWER.**  
The source selection screen is displayed.
- 2 Press the joystick up or down to select the FACTORY SYS mode, then press ►/II/ENTER.**  
The speaker input screen is displayed.
  - *FACTORY SYS mode is displayed when SOURCE or BOTH is set in "Setting the Speaker Input Mode" (page 14).*
  - *Make each setting correctly in "Using the Speaker Input" (page 14) before use this function.*

# HDD Player Operation (Optional)

## Listening to Music of HDD

This device is controllable from the when Alpine HDD player is connected.

- 1 Press SOURCE/POWER.**  
The source selection screen is displayed.
- 2 Press the joystick up or down to select the MM DRIVER, then press ►/II/ENTER.**  
The MM DRIVER mode main screen is displayed.
- 3 Press ◀◀ or ▶▶ to select the desired track.**
  - Returning to the beginning of the current track:**  
Press ◀◀.
  - Fast reverse:**  
Press and hold ◀◀.
  - Advancing to the beginning of the next track:**  
Press ▶▶.
  - Fast forward :**  
Press and hold ▶▶.
- 4 To pause playback, press ►/II/ENTER.**  
Pressing ►/II/ENTER again will resume playback.

# External Audio Processor (Optional)

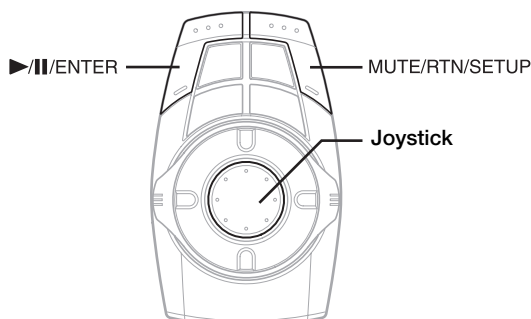

When an external audio processor is connected to this unit, you can operate it from this unit. Some audio processors may not be operated. Explanations below is the case when PXA-H700 or PXA-H701 is connected for example.

Refer also to the operating instructions of the connected audio processor.

- The adjustments or settings performed on the connected audio processor cannot be operated properly from this unit.
- The setting "Setting the Speakers", "Setting Bass Sound Control", and "Graphic Equalizer Adjustments" are not available if the MRD-D550 is connected. Additionally, if the MRD-F350 is connected, the following setting "Setting the MX mode" is not available. Also, the setting content differs between the PXA-H700 and PXA-H701.

### To display the Audio processor mode screen:

To watch a video source, your vehicle must be parked with the ignition key in the ACC or ON position. To do this, follow the procedure below.

- 1 Bring your vehicle to a complete stop at a safe location. Engage the parking brake.
- 2 Keep pushing the foot brake and release the parking brake once then engage it again.
- 3 When the parking brake is engaged for the second time, release the foot brake.

- For automatic transmission vehicles, place the transmission lever in the Park position.

Now, the locking system for the Audio processor mode operation has been released. Engaging the parking brake can reactivate the Audio processor mode, as long as the car's ignition has not been turned off. It is not necessary to repeat the above procedure (1 through 3), of "To display the Audio processor mode screen."

Each time the ignition is turned OFF, perform the procedure of "To display the Audio processor mode screen."

## Adjustment Procedure for Dolby Surround

Make the adjustments described below in order to reproduce Dolby Digital and DTS sound with greater accuracy.

### Adjustment procedure

- 1 Speaker Setup (page 36)**  
(Turning the speakers to be used on and off and setting their response)
- 2 Adjusting the speaker levels (page 37)**  
(Adjusting the signal output level to the various speakers)
- 3 Mixing bass sound to the rear channel (page 37)**  
(Achieving smooth sound in the rear seat by mixing the front audio signals with the rear speaker signals)
- 4 Adjusting the acoustic image (page 37)**  
(Adjusting the acoustic image to achieve a sound as if the center speaker were directly in front of the listener)
- 5 Achieving powerful high volume sound (page 37)**  
(Achieving energetic sound with even greater power, like the sound in a movie theater)
- 6 Adjusting the DVD Level (page 38)**  
(Adjust the volume (signal level) in the Dolby Digital, Pro Logic II, DTS and PCM modes)
- 7 Storing Settings in the Memory (page 38)**  
(Storing all the settings and adjustments made on the VPA-B222 (not only the above settings/adjustments) in the memory)

### In case of combining the Automatic adjustments, etc.

We recommend to make the Automatic adjustments before the Dolby Surround adjustments.

---

## Setting the Speakers

---

- 1 Check that Defeat mode is off (page 10).
- 2 Press and hold **MUTE/RTN/SETUP** for at least 2 seconds.  
The SETUP screen is displayed.
- 3 Press the joystick up or down to select **AP SETUP**, then press the joystick right.  
The AP SETUP screen is displayed.
- 4 Press the joystick up or down to select **SPEAKER SEL**, then press the joystick right.
- 5 Press the joystick left or right to set the connected speaker.  
FRONT1: OFF/FULL (Full Range)/TW (Tweeter)  
FRONT2: OFF/ON  
REAR: OFF/ON  
CENTER: OFF/ON  
SUBWOOFER: OFF/MONO/STEREO
- 6 Repeat step 4 and 5 to set all other speakers.
- 7 Press **MUTE/RTN/SETUP** to return to the previous screen.
  - Set any unconnected speakers to OFF.
  - Settings above can be carried out even when the speaker is set to OFF in "Speaker Setup" (page 36).
  - To use the subwoofer in MONO with PXA-H700 or PXA-H701 connected, connect the subwoofer to the subwoofer output terminal of PXA-H700 or PXA-H701.

---

## Set MX Mode of the External Audio Processor

---

Before performing the operations below, set MX (Media Xpander) mode of the PXA-H700 to "AUTO" when the PXA-H700 is connected.

- 1 Check that Defeat mode is off (page 10).
- 2 Press and hold **MUTE/RTN/SETUP** for at least 2 seconds.  
The SETUP screen is displayed.
- 3 Press the joystick up or down to select **AP SETUP**, then press the joystick right.  
The AP SETUP screen is displayed.
- 4 Press the joystick up or down to select **MX**, then press joystick left or right to select **ON**.
- 5 Press the joystick up or down to select **MX SETUP**, then press the joystick right.

- 6 Press the joystick up or down to select the media that is being played back. Then press the joystick left or right to set the desired MX mode.

### **MX CD (OFF, CD 1 to 3)**

CD mode processes a large quantity of data. This data is used to reproduce the sound cleanly by making use of the data quantity.

### **MX COMPM (OFF, CMPM 1 to 3) / MX SAT (OFF, SAT 1 to 3)**

This corrects information that was omitted at the time of compression. This reproduces a well-balanced sound close to the original.

### **MX FM (OFF, FM 1 to 3)**

The medium to high frequencies become more clear, and produces well balanced sound in all the bands.

### **MX DVD (OFF, MOVIE 1 to 2)**

The dialog portion of the video is reproduced more clearly. (**MUSIC**)

This disk contains a large quantity of data, such as a music clip. MX uses this data to reproduce the sound accurately.

### **MX AUX 1 to 3 (OFF, CMPM, MOVIE, MUSIC)**

Choose the MX mode (CMPM, MUSIC, or MOVIE) that corresponds to the media connected.

- 7 Press **MUTE/RTN/SETUP** to return to the previous screen.

- The contents of MX set here is reflected in PXA-H700 or PXA-H701.
- When OFF is selected, MX effect of each MX mode will be OFF.
- Each music source, such as radio, CD, and MP3 can have its own MX setting.
- MX mode does not function when MX is ON for AM radio.
- MX COMPM is applied for MP3/WMA, MMD, iPod.
- MX SAT is applied for XM, SIRIUS, HD Radio.
- MX mode can only be set for media currently playing back.
- AUX3 can be set only when the optional expansion box VPE-S431 is connected.

---

## X-OVER Adjustment

---

- 1 Check that Defeat mode is off (page 10).
- 2 Press and hold **MUTE/RTN/SETUP** for at least 2 seconds.  
The SETUP screen is displayed.
- 3 Press the joystick up or down to select **AP SETUP**, then press the joystick right.  
The AP SETUP screen is displayed.
- 4 Press the joystick up or down to select **X-OVER**.
- 5 Press the joystick left or right to select **L/R** or **L+R**.
- 6 Press the joystick up or down to select **X-OVER SETUP**, then press the joystick right.
- 7 Press the joystick up or down to select the desired speaker, then press the joystick right.

## 8 Press the joystick up or down to select the desired item, then press the joystick left or right to adjust the crossover.

**FREQUENCY:** Adjust the H.P.F. or L.P.F. cutoff frequency.  
The adjustable bands differ according to the channel (speaker).

**LEVEL:** Adjust the H.P.F. or L.P.F. level.  
Adjustable level: -13 to 0

**SLOPE:** Adjust the H.P.F. or L.P.F. slope.  
Adjustable slope: OFF/-6/-12/-18/-24/-30

To adjust other channels, repeat steps 7 and 8.

## 9 Press MUTE/RTN/SETUP to return to the previous screen.

- When the speaker is set to the "OFF" mode, the X-OVER for that speaker cannot be set. Refer to "Setting the Speakers" (page 33).
- Check the playback frequencies of the connected speakers before adjusting.
- In order to protect the speakers, there is no OFF setting for the subwoofer low pass filter (the slope remains the same).
- The H.P.F. filter cannot be set to OFF (slope OFF) if Tweeter is selected for FRONT1.

## Performing Time Correction Manually (TCR)

Because of the particular conditions inside the vehicle, there can be major differences in the distances between the various speakers and the listening position. It is possible to calculate the optimum correction values and eliminate the time error at the listening position yourself using this function.

- 1 Check that Defeat mode is off (page 10).
- 2 Sit in the listening position (the driver's seat, for example) and measure the distance (in meters) between your head and the various speakers.
- 3 Calculate the difference in distance between the farthest speaker and the other speakers.  

$$L = (\text{distance of farthest speaker}) - (\text{distance of other speakers})$$
- 4 Divide the distances calculated for the different speakers by the speed of sound (343 m/s temperature 20 °C).

This value is the time correction value for the various speakers.

### Concrete examples

Calculating the time correction value for the front left speaker on the diagram below.

Conditions:

Distance between farthest speaker and listening position:  
2.25 m (88-3/4")

Distance between front left speaker and listening position:  
0.5 m (20")

Calculation:

$$L = 2.25 \text{ m (88-3/4")} - 0.5 \text{ m (20")} = 1.75 \text{ m (68-3/4")}$$

Compensation time =  $1.75 \div 343 \times 1000 = 5.1 \text{ (ms)}$

In other words, setting the time correction value for the front left speaker to 5.1 (ms) sets a virtual distance matching the distance to the farthest speaker.

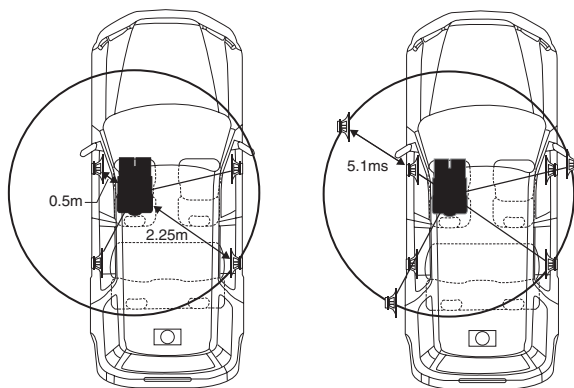

The sound is uneven because the distance between the listening position and the different speakers is different. The difference in the distance between the front left and rear right speakers is 1.75 meters (68-3/4").

Time correction eliminates the difference between the time required for the sound from the different speakers to reach the listening position. Setting the time correction of the front left speaker to 5.1 ms makes it possible to coordinate the distance from the listening position to the speaker.

- 5 Press and hold MUTE/RTN/SETUP for at least 2 seconds.  
The SETUP screen is displayed.
- 6 Press the joystick up or down to select AP SETUP, then press the joystick right.  
The AP SETUP screen is displayed.
- 7 Press the joystick up or down to select TCR.
- 8 Press the joystick left or right to select L/R or L+R.  
L/R: Different adjustment values can be set for the left and right channels.  
L+R: Sets the same adjustment values for the left and right channels.
- 9 Press the joystick up or down to select TCR SETUP, then press the joystick right.
- 10 Press the joystick up or down to select the desired speaker.
- 11 Press the joystick left or right to adjust the calculated time correction value (0.00 to 20.00ms). (1step=0.05ms)  
Time correction value changes continuously by pressing and holding the joystick.
- 12 Press MUTE/RTN/SETUP to return to the previous screen.
  - When the speaker is set to the "OFF" mode, the TCR for that speaker cannot be set. Refer to "Setting the Speakers" (page 33).
  - The adjustment value for FRONT2 (Speakers) which is adjusted in time correction, is also applied to the front speakers in "Setting Bass Focus" (page 36).
  - The adjustment (AUTO TCR) cannot be automatically set on this unit.

---

## Phase Switching

---

- 1 Check that the Defeat mode is off (page 10).
- 2 Press and hold **MUTE/RTN/SETUP** for at least 2 seconds.  
The SETUP screen is displayed.
- 3 Press the joystick up or down to select **AP SETUP**, then press the joystick right.  
The AP SETUP screen is displayed.
- 4 Press the joystick up or down to select **PHASE SETUP**, then press the joystick right.
- 5 Press the joystick up or down to select the desired speaker.
- 6 Press the joystick left or right to switch the phase (0° or 180°).
- 7 Press **MUTE/RTN/SETUP** to return to the previous screen.

---

## Graphic Equalizer Adjustments

---

The graphic equalizer allows you to modify the sound using 31 bands each for the front (left and right), rear (left and right) and center speakers. An additional 10 bands are available for the subwoofer. This allows you to customize the sound to suit your taste.

- 1 Check that the Defeat mode is off (page 10).
- 2 Press and hold **MUTE/RTN/SETUP** for at least 2 seconds.  
The SETUP screen is displayed.
- 3 Press the joystick up or down to select **AP SETUP**, then press the joystick right.  
The AP SETUP screen is displayed.
- 4 Press the joystick up or down to select **G-EQ**.
- 5 Press the joystick left or right to select **L/R** or **L+R**.  
L/R: Different adjustment values can be set for the left and right channels.  
L+R: Sets the same adjustment values for the left and right channels.  
When parametric EQ is adjusted, this setting will be turned off.
- 6 Press the joystick up or down to select **G-EQ SETUP**, then press the joystick right.
- 7 Press the joystick up or down to select the desired channel, then press the joystick right.
- 8 Press the joystick up or down to select the desired frequency.
- 9 Press the joystick left or right to adjust the level of the desired frequency.  
Adjustable level: -9 to +9  
To adjust other frequencies, repeat steps 8 and 9.  
To adjust other channels, repeat steps 7 and 9.

- 10 Press **MUTE/RTN/SETUP** to return to the previous screen.

- When the speaker is set to the "OFF" mode, the graphic equalizer for that speaker cannot be set. Refer to "Setting the Speakers" (page 33).
- Check the playable frequency ranges of the connected speakers before making the equalizer adjustments. If the speaker's playable frequency range is 55 Hz to 30 kHz, for example, adjusting the 40 Hz or 20 Hz band has no effect. Additionally, you may overload and damage the speakers.
- When graphic EQ is adjusted, the adjustment for parametric EQ becomes ineffective.

---

## Parametric Equalizer Adjustments

---

The frequency bands of the graphic equalizer are fixed. This makes it very difficult to correct for undesired peaks and dips at specific frequencies. The parametric equalizer's center frequency can be tuned to these specific frequencies. Then, the bandwidth (Q) and level are fine-tuned, independently, to make the necessary corrections. The parametric equalizer function is an advanced tool for serious audiophiles.

- 1 Check that Defeat mode is off (page 10).
- 2 Press and hold **MUTE/RTN/SETUP** for at least 2 seconds.  
The SETUP screen is displayed.
- 3 Press the joystick up or down to select **AP SETUP**, then press the joystick right.  
The AP SETUP screen is displayed.
- 4 Press the joystick up or down to select **P-EQ**.
- 5 Press the joystick left or right to select **L/R** or **L+R**.  
L/R: Different adjustment values can be set for the left and right channels.  
L+R: Sets the same adjustment values for the left and right channels.  
When graphic EQ is adjusted, this setting will be turned off.
- 6 Press the joystick up or down to select **P-EQ SETUP**, then press the joystick right.
- 7 Press the joystick up or down to select the desired channel, then press the joystick right.
- 8 Press the joystick up or down to select the desired band, then press the joystick right.
- 9 Press the joystick up or down to select the desired item, then press the joystick left or right to adjust the desired mode.  
To adjust other bands, repeat steps 8 and 9.  
To adjust other channels, repeat steps 7 and 9.  
FREQUENCY: Selects the frequency.  
LEVEL: Adjusts the level.  
Adjustable level: -9 to +9  
Q: Adjust the bandwidth.  
Adjustable bandwidth: 0.5/1/2/3/4/5

**10** Press **MUTE/RTN/SETUP** to return to the previous screen.

- When the speaker is set to the “OFF” mode, the parametric equalizer for that speaker cannot be set. Refer to “Setting the Speakers” (page 33).
- It is not possible to adjust the frequencies of adjacent bands within 7 steps.
- Check the playable frequency ranges of the connected speakers before making the equalizer adjustments. If the speaker’s playable frequency range is 55 Hz to 30 kHz, for example, adjusting the 40 Hz or 20 Hz band has no effect. Additionally, you may overload and damage the speakers.
- When the parametric EQ is adjusted, the adjustment for graphic EQ becomes ineffective.

## Setting Bass Sound Control

- 1** Check that Defeat mode is off (page 10).
- 2** Press and hold **MUTE/RTN/SETUP** for at least 2 seconds.  
The SETUP screen is displayed.
- 3** Press the **joystick up or down** to select **AP SETUP** and press the **joystick right**.  
The AP SETUP screen is displayed.
- 4** Press the **joystick up or down** to select **B.SOUND CNTL**, then press the **joystick right**.

### Setting Bass Compressor

You can adjust the sound of low frequencies as desired.

- 5** Press the **joystick up or down** to select **BASS COMP**.
- 6** Press the **joystick left or right** to select the desired mode.  
Bass sound is emphasized more as the mode is sequentially switched as MODE1 → 2 → 3, offering you vivid low frequencies.  
Select OFF when the setting is not necessary.  
  
Press MUTE/RTN/SETUP to return to the previous screen.

### Setting Bass Focus

Using the previously specified delay number (time difference) allows you to set a time difference between the front-rear/left-right speakers. Namely, it enables a time correction based on your preference. With an initial delay of 0.05 ms for each of the 0 to 400 steps, audible time correction can be achieved.

- 5** Press the **joystick up or down** to select the desired speaker.
  - 6** Press the **joystick left or right** to adjust the front, rear, left and right speakers.
  - 7** Repeat step 5 and 6 to set other speakers.
- Any setting in Bass Focus is applied in time correction, too.
  - Press **MUTE/RTN/SETUP** to return to the previous screen.

## Speaker Setup

The PXA-H700 or PXA-H701 can be set according to the playable frequency range of your speakers.

Check the playable frequency range of the speakers (not including the subwoofer) before performing this operation to verify whether the speakers can play low frequencies (of about 80 Hz or less).

- Avoid stopping, pausing, switching the disc, cueing, fast-forwarding or switching the audio channel of this unit while making this adjustment. The setting is canceled if Decode mode is switched.

- 1** Check that Defeat mode is off (page 10).
- 2** Press and hold **MUTE/RTN/SETUP** for at least 2 seconds.  
The SETUP screen is displayed.
- 3** Press the **joystick up or down** to select **AP SETUP**, then press the **joystick right**.  
The AP SETUP screen is displayed.
- 4** Press the **joystick up or down** to select **SPEAKER SETUP**, then press the **joystick right**.
- 5** Press the **joystick up or down** to select the desired speaker.
- 6** Press the **joystick left or right** to select the speaker characteristic.  
  
OFF\*<sup>1</sup>: When no speaker is connected.  
SMALL: When a speaker that cannot play low frequencies (80 Hz or less) is connected.  
LARGE\*<sup>2</sup>: When a speaker that can play low frequencies (80 Hz or less) is connected.  
  
\*<sup>1</sup> It is not possible to set the front speakers to “OFF”.  
\*<sup>2</sup> If the front speakers are set to “SMALL”, the rear and center speakers cannot be set to “LARGE”.

- 7** Repeat step 5 and 6 to set each speaker.

- If the center speaker is turned “OFF”, the center channel’s audio signals are added to the audio signals output from the front speakers.
- If you set the speaker response to “OFF”, also set the speaker setting to “OFF” (page 33).
- Perform the setup for all the speakers (“Front,” “Center,” “Rear” and “Subwoofer”). Otherwise, the sound may not be balanced.
- When the center speaker is set to “OFF”, the setting is ineffective even if center is set with this function.
- Through changing the settings on each speaker, a change in the output of the other speakers may occur due to the setting requirements.
- When using PRO LOGIC II, if the rear speaker is set to “LARGE”, there will be no output from the subwoofer.

## Setting of Dolby Digital

- 1 **Check that Defeat mode is off (page 10).**
- 2 **Press and hold MUTE/RTN/SETUP for at least 2 seconds.**  
The SETUP screen is displayed.
- 3 **Press the joystick up or down to select AP SETUP, then press the joystick right.**  
The AP SETUP screen is displayed.
- 4 **Press the joystick up or down to select MULTI CH SET, then press the joystick right.**  
The MULTI CH SET screen is displayed.
- 5 **Press the joystick up or down to select the desired item.**  
Set the items below as you desire.

### Adjusting the acoustic image

In most installations, the center speaker must be placed directly between the front passenger and driver. Using this function, the center channel information is distributed to the left and right speakers. This creates an acoustic image simulating a center speaker directly in front of each listener. Adjusting the center width in PL II MUSIC (see "Using the Pro Logic II Mode," page 38), makes this function ineffective.

- *Avoid stopping, pausing, switching the disc, cueing, fast-forwarding or switching the audio channel of this unit while making this adjustment. The setting is canceled if the Decode mode is switched.*
  - 1 Press the joystick left or right to select **ON** of BI-PHANTOM.
  - 2 Press the joystick down to select **BI-PHANTOM LV**.
  - 3 Press the joystick left or right to adjust the level.  
The level can be adjusted within the range of -5 to +5. The higher the level, the more the position of the center speaker is shifted to the sides.  
The BI-PHANTOM function is turned off when setting to **OFF**.
- *This adjustment is effective when the setting of the center speaker to **SMALL** or **LARGE** in the speaker setup settings.*
- *This adjustment is ineffective when the speaker is set to **CENTER OFF** in "Setting the Speakers" (page 33).*

### Mixing bass sound to the rear channel

This function mixes the front channel audio signals to the audio signals output from the rear speakers, improving the sound in the vehicle's rear seat.

- *Avoid stopping, pausing, switching the disc, cueing, fast-forwarding or switching the audio channel of this unit while making this adjustment. The setting is canceled if the Decode mode is switched.*
  - 1 Press the joystick left or right to select **ON** of REAR MIX.
  - 2 Press the joystick down to select **MIX LEVEL**.
  - 3 Press the joystick left or right to adjust the level.  
The level can adjusted in five steps: -6, -3, 0, +3 and +6. The higher the level, the more bass is output from the rear speakers. (The effect differs depending on the software (DVD, etc.)).  
The REAR MIX function is turned off when set to **OFF**.
- *This adjustment is ineffective when the rear speaker setup setting is set to "OFF".*
- *For linear PCM signals, the voice is output from the rear speaker regardless of the REAR FILL and REAR MIX setting.*

### Achieving powerful high volume sound

With Dolby Digital, the dynamic range is compressed so that powerful sound can be achieved at regular volume levels. This compression can be canceled to achieve an energetic sound with even greater power, like the sound in a movie theater.

This function works only in the Dolby Digital mode.

Press the joystick left or right to select **STD** or **MAX.** of LISTENING.

**STD:** For powerful sound at regular volume levels  
**MAX.:** For powerful sound at high volumes

- *Keep the volume to a level at which sounds outside the vehicle can still be heard.*

### Adjusting the speaker levels

The test tones help to make the volume adjustments of the different speakers. When levels are equal, a strong sense of presence can be heard from the different speakers at the listening position.

- *Avoid stopping, pausing, switching the disc, cueing, fast-forwarding or switching the audio channel of this unit while making this adjustment. The setting is canceled if the decode mode is switched.*
  - 1 Press the joystick left or right to select **ON** of OUTPUT.  
Test tone output is repeated for each of the different speaker channels. They will be repeated in the order shown below.  
If no operation is performed for 2 seconds, the channel switches to the next channel.  
Left → Center → Right → Right Surround →  
Left surround → Left
  - 2 Press the joystick down to select **OUTPUT LEVEL**.
  - 3 Press the joystick left or right to balance the output from all the speakers.
    - The adjustment range for the different speakers is -10 dB - +10 dB.
    - Adjust based on the front speakers.
- *If a speaker is set to off mode, that speaker's level adjustment cannot be made. Refer to "Speaker Setup" (page 36).*

---

## Adjusting the DVD Level

---

The volume (signal level) for Dolby Digital, Dolby PL II, DTS and PCM modes can be set.

- *Avoid stopping, pausing, switching the disc, cueing, fast-forwarding or switching the audio channel of this unit while making this adjustment. The setting is canceled if the Decode mode is switched.*

- 1 Check that Defeat mode is off (page 10).**
- 2 Press and hold MUTE/RTN/SETUP for at least 2 seconds.**  
The SETUP screen is displayed.
- 3 Press the joystick up or down to select AP SETUP, then press the joystick right.**  
The AP SETUP screen is displayed.
- 4 Press the joystick up or down to select DVD LEVEL, then press the joystick right.**  
The DVD LEVEL screen is displayed.
- 5 Press the joystick up or down to select the desired mode.**
- 6 Press the joystick left or right to adjust level.**  
The level can be adjusted in the range of -5 to +5.
- 7 Repeat step 5 and 6 to set each level.**

---

## Storing Settings in the Memory

---

Adjustment or setting contents can be stored.

Contents that can be stored vary depends on the audio processor used.

- 1 Check that Defeat mode is off (page 10).**
- 2 Press and hold MUTE/RTN/SETUP for at least 2 seconds.**  
The SETUP screen is displayed.
- 3 Press the joystick up or down to select AP SETUP, then press the joystick right.**  
The AP SETUP screen is displayed.
- 4 Press the joystick up or down to select PRESET MEMORY, then press the joystick right.**
- 5 Press the joystick up or down to select any one of the preset numbers (1 through 6), then press ►/||/ENTER.**  
The setting contents are stored.

- *The stored contents will not be deleted even when the battery power cord is detached.*

---

## Calling up the Preset Memory

---

- 1 Check that Defeat mode is off (page 10).**
- 2 Press and hold MUTE/RTN/SETUP for at least 2 seconds.**  
The SETUP screen is displayed.
- 3 Press the joystick up or down to select AP SETUP, then press the joystick right.**  
The AP SETUP screen is displayed.
- 4 Press the joystick up or down to select PRESET CALL, then press the joystick right.**
- 5 Press the joystick up or down to select any one of the preset numbers (1 through 6), then press ►/||/ENTER.**

- *It takes a few moments to call up the preset memory.*

---

## Using the Pro Logic II Mode

---

Pro Logic processing can be conducted on the music signals recorded on two channels to achieve Dolby Pro Logic II surround sound. For two-channel Dolby Digital and DTS signals, there is also a "REAR FILL" function for outputting the signals of the front channel to the rear channel.

- 1 Check that Defeat mode is off (page 10).**
- 2 Press and hold MUTE/RTN/SETUP for at least 2 seconds.**  
The SETUP screen is displayed.
- 3 Press the joystick up or down to select AP SETUP, then press the joystick right.**  
The AP SETUP screen is displayed.
- 4 Press the joystick up or down to select D PLII/REAR, then press the joystick right.**
- 5 Press the joystick left or right to select the desired mode of D PLII/REAR.**

**MOVIE:** Suits the stereo TV shows and all programs encoded in Dolby Surround. It improves the sound field directivity to near that of discrete 5.1-channel sound.

**MUSIC:** Can be used for all stereo music recordings, and provides a wide, deep sound field.

**R.FILL:** Depending on the input signals, the sound may only be output from the front speakers. In this case, the "REAR FILL" function can be used to output signals from the rear speakers as well.

**OFF:** Turns D PLII/REAR FILL function to OFF.



If **MUSIC** is selected, the center width can be adjusted with the following operations.

This function offers the optimum vocal position by adjusting the center channel position between the center speaker and the L/R speaker (The adjustments established in "Adjusting the acoustic image" (page 37) are ineffective while this function is activated).

- 1 Press the joystick down to select **CENTER WIDTH**, then press the joystick left or right to select **ON**.
- 2 Press the joystick left or right to adjust the level.  
The level can be adjusted between 0 to 7. When the level increases, the center channel position moves from the center speaker position to both sides.  
The center width control is canceled when set to **OFF**.

- This adjustment is effective when the setting of the center speaker is **SMALL** or **LARGE** in the speaker setup settings.
- Avoid stopping, pausing, switching the disc, cueing, fast-forwarding or switching the audio channel of this unit while making this adjustment. The setting is canceled if the Decode mode is switched.
- This adjustment is ineffective when the speaker is set to **CENTER OFF** in "Setting the Speakers" (page 33).
- This function only works with two-channel signals. This operation is ineffective when 5.1-channel DTS or Dolby Digital signals are input.
- If the setting of **REAR FILL** is made when **REAR MIX** is **ON**, sound is unchanged in the rear fill setting because **REAR MIX** is given priority during 2 channel decoder other than linear PCM.
- For linear PCM signals, the voice is output from the rear speaker regardless of the **REAR FILL** and **REAR MIX** setting.
- Pressing **MUTE/RTN/SETUP** will return to the previous screen.

## Linear PCM Setting

The output when playing discs recorded in linear PCM can be set to 2 or 3 channels.

- 1 Check that **Defeat mode** is off (page 10).
- 2 Press and hold **MUTE/RTN/SETUP** for at least 2 seconds.  
The **SETUP** screen is displayed.
- 3 Press the joystick up or down to select **AP SETUP**, then press the joystick right.  
The **AP SETUP** screen is displayed.
- 4 Press the joystick up or down to select **PCM MODE**.
- 5 Press the joystick left or right to select **2CH** or **3CH**.

- 2CH: 2ch output (L/R)
- 3CH: 3ch output (L/R/CENTER)

- This adjustment is ineffective when the speaker is set to **CENTER OFF** in "Setting the Speakers" (page 33).

## Soft button operation

If the Alpine touch panel compatible monitor is connected to this unit, touch operation can be performed by directly touching the monitor. Refer to each section for details.

- Operation may differ depending on the connected device. Refer to owner's manual of the connected device.

## Basic operation

The following example for the radio screen and source selection screen explains for basic operation.

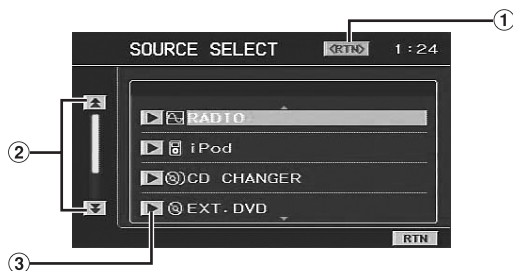

- 1 <RTN>  
Returns to the main source screen.
- 2 ▲/▼  
Scrolls the list.
- 3 ►  
Selects the item.

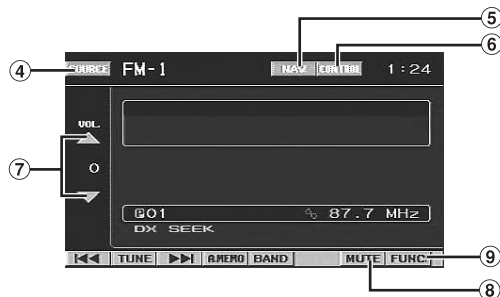

- 4 SOURCE (page 7)  
The source selection screen is displayed.
- 5 NAV. (page 28)  
The Navigation screen is displayed.
- 6 CONTROL  
Displays the function screen on the connected touch panel compatible with the monitor.
- 7 VOL. ▲/▼ (page 7)  
Adjusts the volume.
- 8 MUTE (page 7)  
Turns mute on and off.
- 9 FUNC.  
Displays the FUNCTION screen of each source.



- ⑩ >> If there is a hierarchical list, >> is displayed, and touching will change to the list screen.
- ⑪ RTN Returns to the previous screen.

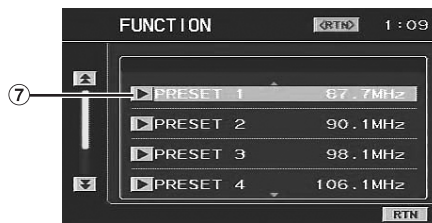

- ⑦ ▶ (page 8) Enters the preset number.

## Radio Operation

### Display example for the radio main screen

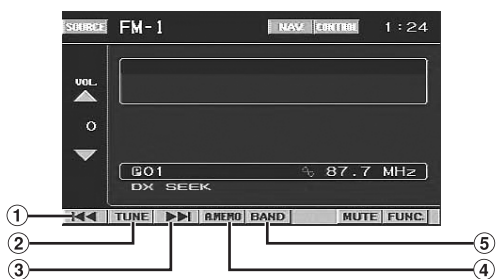

- ① <<< (pages 7, 8) Searches and receives a channel automatically (distance mode or local mode). <<< (pages 7, 8) Changes down through channels on by one (manual mode).
- ② TUNE (page 7) Changes the tuning mode. DX SEEK (<<<, >>>) → SEEK (<<<, >>>) → OFF (<<<, >>>) → DX SEEK
- ③ >>> (pages 7, 8) Searches and receives a channel automatically (distance mode or local mode). >>> (pages 7, 8) Changes down through channels on by one (manual mode).
- ④ A.MEMO (page 8) Memorizes automatically.
- ⑤ BAND (page 7) Changes the band.

### Display example for function screen



- ⑥ >> (page 8) When you store/recall a preset number, the display changes to the preset number screen.

## Setup Operation

“Adjusting the Audio” (page 9), “Rear Entertainment Function” (page 11) and “External Audio Processor (Optional)” (page 32) are operated in the same way.

### Display example for the function screen

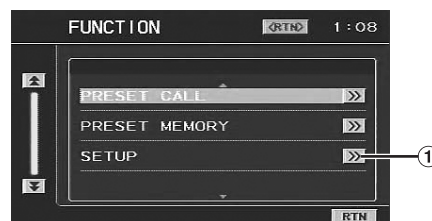

- ① (SETUP) >> Displays SETUP screen.

### Display example for setup screen

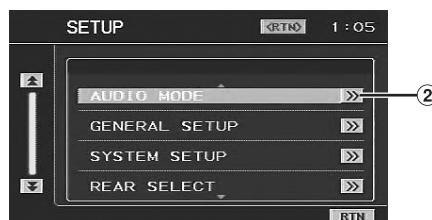

- ② >> If there is a hierarchical list, >> is displayed, and touching will change to the list screen.



- ③ </> Adjusts and sets by touching.

# CD/MP3/WMA Operation

## Display example for MP3/WMA main screen

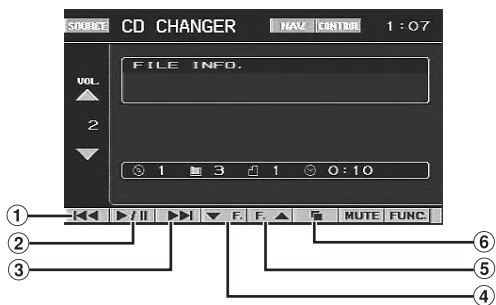

- ① ◀◀ (pages 17, 18)  
Finds the beginning of the current track. Touch and hold to play fast-reverse.
- ② ▶/|| (pages 17, 18)  
Pauses and plays back.
- ③ ▶▶ (pages 17, 18)  
Finds the beginning of the next track. Touch and hold to play fast-forward.
- ④ ▼F. (page 17)  
Selects previous folder.
- ⑤ F.▲ (page 17)  
Selects next folder.
- ⑥ ◻ (page 18)  
Enters folder/file search mode.

• “▲F”, “F.▼” and “◻” are not displayed during CD playback.

## Display example for search screen



- ⑦ ▶ (page 18)  
Enters the selected folder/file.
- ⑧ >> (page 18)  
If there is a file in the folder, folders are displayed, and touching will change to the file list screen.

## Display example for the function screen

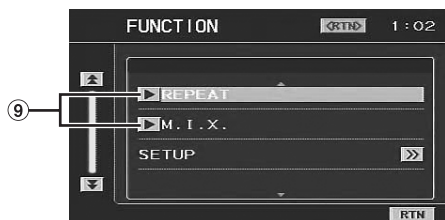

- ⑨ ▶ (REPEAT), ▶ (M.I.X.) (page 18)  
Each touch changes to repeat or M.I.X. mode.

## Display example for when connecting a changer

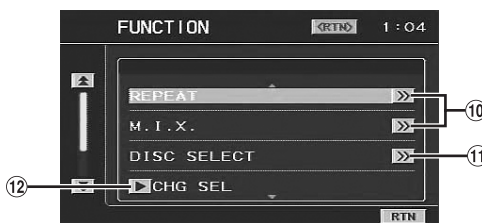

- ⑩ (REPEAT) >>, (M.I.X.) >> (page 18)  
Changes to the selection screen of M.I.X. or repeat mode. Touch ▶ to confirm mode in the selection screen.
- ⑪ (DISC SELECT) >> (page 17)  
Displays disc selection screen. Touch ▶ to confirm disc in the selection screen.
- ⑫ ▶ (CHG SEL) (page 18)  
Displayed when two changers are connected. Touch to change the changer.

# DVD/Video CD Operation

- The display item differs according to disc and connected device.
- Some soft buttons may not be operational.

## Display example for DVD main operation screen

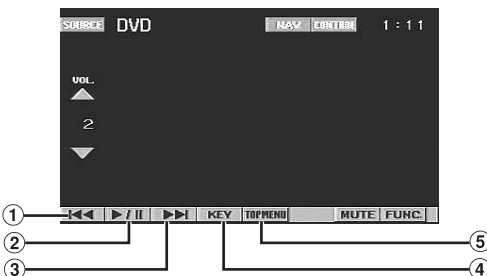

- ① ◀◀ (page 20)  
Finds the beginning of track/chapter. Touching and holding plays fast-reverse.
- ② ▶/|| (page 20)  
Pauses and plays back.
- ③ ▶▶ (page 20)  
Finds the beginning of a track/chapter. Touching and holding plays fast-forward.
- ④ KEY (page 20)  
The DVD menu operation screen is displayed.
- ⑤ TOP MENU (page 21)  
The DVD top menu screen is displayed.

**Display example for DVD menu operation screen**

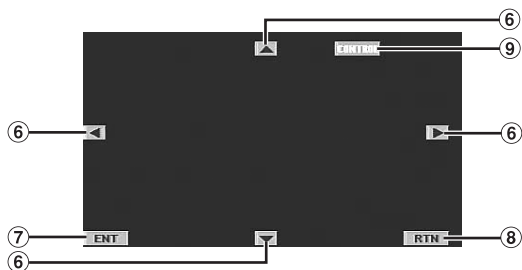

- ⑥ ▲▼◀▶  
Moves an item displayed on the screen.
- ⑦ ENT  
Enters the selected item.
- ⑧ RTN  
Returns to the previous screen.
- ⑨ CONTROL  
Displays the main operation screen.

**Display example for function screen**

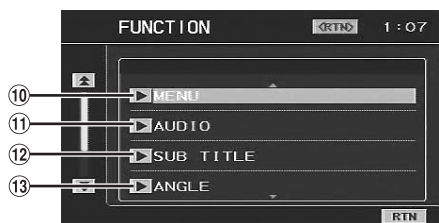

- ⑩ ▶ (MENU) (page 22)  
Displays menu screen.
- ⑪ ▶ (AUDIO) (page 21)  
Changes audio language.
- ⑫ ▶ (SUB TITLE) (page 22)  
Changes subtitle language.
- ⑬ ▶ (ANGLE) (page 22)  
Changes angle.
- ⑭ ▶ (STOP/PRE STOP) (page 21)  
Stops/pauses playback.
- ⑮ ▶ (REPEAT) (page 21)  
Changes repeat mode.

# SAT Radio Operation

**Display example for XM main screen**

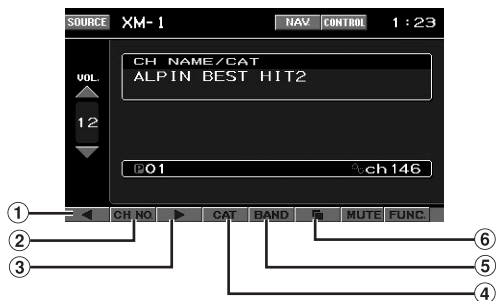

- ① ◀ (page 23)  
Changes down through channel one by one. Touching and holding changes continuously.
- ② CH NO., CH. NAME (page 23)  
Switches the tuning method (by channel number or channel name).
- ③ ▶ (page 23)  
Changes up through channel one by one. Touching and holding changes continuously.
- ④ CAT (page 23)  
The category mode screen is displayed.
- ⑤ BAND (page 23)  
Changes the band.
- ⑥ ◻ (page 25)  
The category search screen is displayed.

**Display example for SIRIUS main screen**

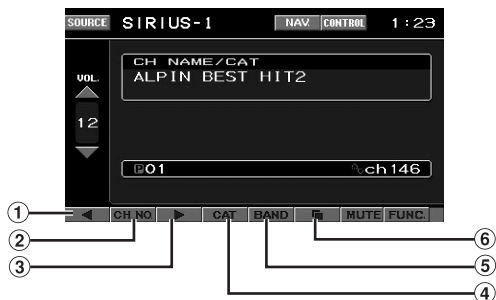

- ① ◀ (page 23)  
Decreases channel one by one. Touching and holding changes continuously.
- ② CH NO., CH. NAME (page 23)  
Switches the tuning way (channel number or channel name).
- ③ ▶ (page 23)  
Increases channel one by one. Touching and holding changes continuously.
- ④ CAT (page 23)  
The category mode screen is displayed.
- ⑤ BAND (page 23)  
Changes the band.
- ⑥ ◻ (page 25)  
The category search screen is displayed.

**Display example for search screen**

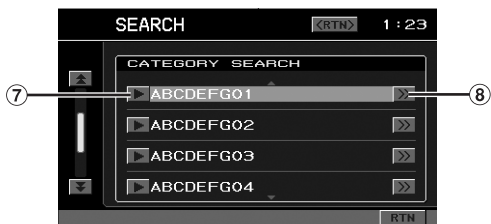

- ⑦ ▶ (page 25)  
Enters the selected category.
- ⑧ >> (page 25)  
The channel search screen is displayed.  
Touching ▶ on the channel search screen will execute a channel.

**Display example for function screen**

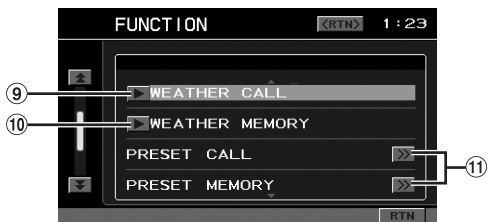

- ⑨ ▶ (WEATHER CALL) (page 25)  
The stored weather or traffic channel is recalled.
- ⑩ ▶ (WEATHER MEMORY) (page 25)  
The received weather or traffic channel is stored.
- ⑪ (PRESET CALL) >> (page 24)  
When the preset number is stored or recalled, the display changes to the preset number.

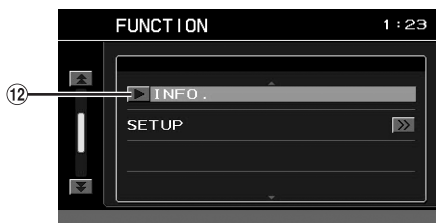

- ⑫ ▶ (INFO.) (page 23)  
The information screen is displayed.

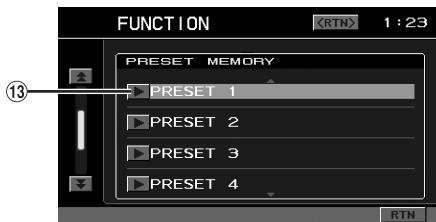

- ⑬ ▶ (page 24)  
Touch ▶ to execute the selected preset number.

# iPod® Operation

**Display example for iPod main screen**



- ① ⏮ (page 25)  
Finds the beginning of a song. Touching and holding will go fast-reverse.
- ② ▶/⏸ (page 25)  
Pauses and plays back.
- ③ ⏭ (page 25)  
Finds the beginning of a song. Touching and holding fast-forwards a song.
- ④ ▼ D. (page 27)  
Selects from playlist/artist/album.
- ⑤ ▲ D. (page 27)  
Selects from playlist/artist/album.
- ⑥ 🗑 (page 26)  
The search mode screen is displayed.

**Display example for search screen**

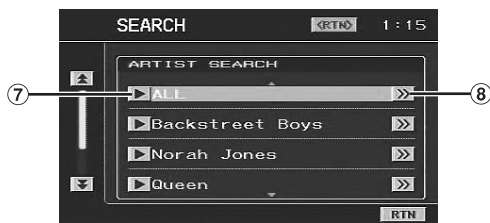

- ⑦ ▶ (page 26)  
Enters the selected playlist/artist/album/song.
- ⑧ >> (page 26)  
If there is a hierarchy in playlist/artist/album, lists are displayed, and the list screen will change by touching.

**Display example for function screen**

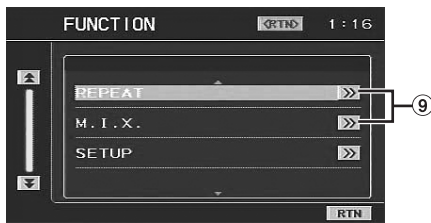

- ⑨ (REPEAT) >>, (M.I.X.) >> (page 27)  
Changes to the selection screen of M.I.X. or repeat mode.  
Touch ▶ to confirm mode in selection screen.

## TV Operation

### Display example for TV main screen

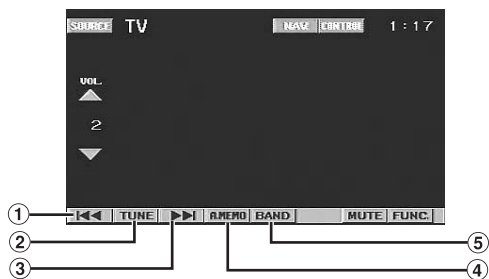

- ① ◀◀ (page 29)  
Decreases channels one by one (Manual mode).  
Touching and holding searches and receives a channel automatically (Auto seek mode).  
◀◀ (page 29)  
Decreases the preset number one by one.
- ② TUNE (page 29)  
Changes the tuning way (Manual mode, auto seek mode and preset number).
- ③ ▶▶ (page 29)  
Increases channels one by one (Manual mode).  
Touching and holding searches and receives a channel automatically (Auto seek mode).  
▶▶ (page 29)  
Increases the preset number one by one.
- ④ A.MEMO (page 29)  
Memorizes automatically.
- ⑤ BAND (page 29)  
Changes the band.

### Display example for the function screen

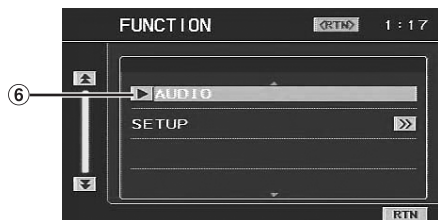

- ⑥ ▶ AUDIO (page 29)  
Changes audio.

## HDD Player Operation

### Display example for MM DRIVER main screen

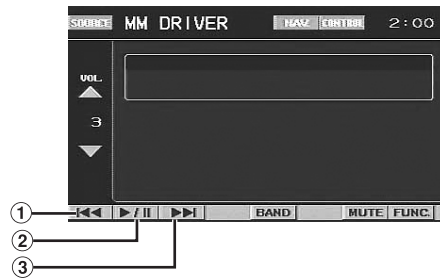

- ① ◀◀ (page 31)  
Finds the beginning of a song. Touch and hold to go continuously back through songs.
- ② ▶/II (page 31)  
Pauses and plays back.
- ③ ▶▶ (page 31)  
Finds the beginning of a song. Touch and hold to go continuously forward through songs.

# Information

## In Case of Difficulty

If you encounter a problem, please turn the power off, then on again. If the unit is still not functioning normally, please review the items in the following checklist. This guide will help you isolate the problem if the unit is at fault. Otherwise, make sure the rest of your system is properly connected, or then consult your authorized Alpine dealer.

### Basic

#### No function or display.

- Vehicle's ignition is off.
  - If connected according to the instructions, the unit will not operate with the vehicle's ignition off.
- Improper power lead connections.
  - Check power lead connections.
- Blown fuse.
  - Check the fuse on the battery lead of the unit; replace with the proper value if necessary.
- Internal micro-computer malfunctioned due to interference noise, etc.
  - Press the RESET switch with a ballpoint pen or other pointed article.

#### No sound or unnatural sound.

- Incorrect setting of volume/balance/fader controls.
  - Readjust the controls.
- Connections are not properly or securely made.
  - Check the connections and firmly connect.

#### Screen not displayed.

- Connections to the DVD, CD player, navigation system are not securely made.
  - Check the connections and firmly connect.

#### Navigation system inoperative.

- Connections to the navigation system are incorrect.
  - Check the connections with the navigation system and connect the cables correctly and firmly.

#### The remote control is inoperative.

- The remote control sensor setting of "Rear Entertainment Function" is not set to this unit.
  - Set for this unit.

### Radio

#### Unable to receive stations.

- No antenna, or open connection in the antenna cable.
  - Make sure the antenna is properly connected; replace the antenna or cable if necessary.

#### Unable to tune stations in the seek mode.

- You are in a weak signal area.
  - Make sure the tuner is in DX mode.
- If the area you are in is a primary signal area, the antenna may not be grounded and connected properly.
  - Check your antenna connections; make sure the antenna is properly grounded at its mounting location.
- The antenna may not be the proper length.
  - Make sure the antenna is fully extended; if broken, replace the antenna with a new one.

#### Broadcast is noisy.

- The antenna is not the proper length.
  - Extend the antenna fully; replace it if it is broken.
- The antenna is poorly grounded.
  - Make sure the antenna is grounded properly at its mounting location.
- The station signal is weak and noisy.
  - If above solution does not work, tune in another station.

#### Indication for CD changer

### HI-TEMP

- Protective circuit is activated due to high temperature.
  - The indicator will disappear when the temperature returns to within operation range.

### ERROR01

- Malfunction in the CD Changer.
  - Consult your Alpine dealer. Press the magazine eject button and pull out the magazine. Check the indication. Insert the magazine again. If the magazine cannot be pulled out, consult your Alpine dealer.
- Magazine ejection not possible.
  - Press the magazine eject button. If the magazine does not eject, consult your Alpine dealer.

### ERROR02

- A disc is left inside the CD Changer.
  - Press the Eject button to activate the eject function. When the CD Changer finishes the eject function, insert an empty CD magazine into the CD Changer to receive the disc left inside the CD Changer.

### NO MAGAZINE

- No magazine is loaded into the CD Changer.
  - Insert a magazine.

### NO DISC

- No indicated disc.
  - Choose another disc.

## Indication for SAT Receiver Mode

### **ANTENNA**

- The XM or SIRIUS antenna is not connected to the XM or SIRIUS radio module.
    - Check whether the XM or SIRIUS antenna cable is attached securely to the XM or SIRIUS radio module.
- 

### **UPDATING**

- Radio is being updated with latest encryption code.
    - Wait until encryption code is being updated. Channels 0 and 1 should function normally.
- 

### **NO SIGNAL** (XM mode)

### **ACQUIRING** (SIRIUS mode)

- XM or SIRIUS signal is too weak at the current location.
    - Wait until the car reaches a location with a stronger signal.
- 

### **LOADING** (XM mode)

- Radio is acquiring audio or program information.
    - Wait until the radio has received the information.
- 

### **OFF AIR** (XM mode)

### **ACQUIRING** (SIRIUS mode)

- The channel currently selected has stopped broadcasting.
    - Select another channel.
- 

### **-----**

- The user has selected a channel number that does not exist or is not subscribed to.
    - The unit will revert back to the previously selected channel.
  - There is no artist name/feature, song/program title, or additional information associated with the channel at that time.
    - No action needed.
- 

## Indication for iPod Mode

### **NO iPod**

- The iPod is not connected.
    - Make sure the iPod is correctly connected.
      - Make sure the cable is not bent excessively.
  - The iPod's battery remains low.
    - Refer to the iPod's documentation and charge the battery.
- 

### **NO SONG**

- There are no songs in the iPod.
    - Download songs to the iPod and connect to the VPA-B222.
- 

### **ERROR01**

- Communication error
    - Turn the ignition key off, and then set to ACC or ON again.
    - Check the display by reconnecting between the iPod and the adapter, using the iPod cable.
- 

### **ERROR02**

- Caused by the iPod Software Version not being compatible with this unit.
  - Update the iPod Software Version to be compatible with this unit.



---

# Specifications

---

## **FM TUNER SECTION**

Tuning Range	87.7 – 107.9 MHz
Mono Usable Sensitivity	9.3 dBf (0.8 $\mu$ V/75 ohms)
50 dB Quieting Sensitivity	13.5 dBf (1.3 $\mu$ V/75 ohms)
Alternate Channel Selectivity	80 dB
Signal-to-Noise Ratio	65 dB
Stereo Separation	35 dB
Capture Ratio	2.0 dB

## **AM TUNER SECTION**

Tuning Range	530 – 1,710 kHz
Usable Sensitivity	22.5 $\mu$ V/27.0 dB

## **GENERAL**

Power Requirement	14.4 V DC (11–16 V allowable)
Operating temperature	+32°F to +113°F (0°C to + 45°C)
Power Output	18 W RMS $\times$ 4*
* Primary amplifier ratings per CEA-2006 Standard	
• Power output: measured at 4 Ohms and $\leq$ 1% THD+N	
• S/N: 80 dBA (reference: 1 W into 4 Ohms)	
Output Voltage	2,000 mV/10k ohms
Bass	+20/-14 dB at 100 Hz
Treble	$\pm$ 14 dB at 10 kHz
Weight	1.2 kg (2 lbs. 10 oz)
Audio output level	
Preout (Front, Rear):	2V/10k ohms (max.)
Preout (Subwoofer):	2V/10k ohms (max.)
Auxout:	1.2V/10k ohms
Ai-NET:	850 mV

## **CHASSIS SIZE**

Width	275 mm (10-13/16")
Height	40 mm (1-9/16")
Depth	170 mm (6-3/4")

## **Commander**

Width	53 mm (2-1/16")
Height	29 mm (1-1/8")
Depth	87 mm (3-7/16")
Weight	50 g (1.8 oz) (holder excluded)

---

---

# Installation and Connections

Before installing or connecting the unit, please read the following and pages 4 to 5 of this manual thoroughly for proper use.

## Warning

---

### MAKE THE CORRECT CONNECTIONS

Failure to make the proper connections may result in fire or product damage.

---

### USE ONLY IN CARS WITH A 12 VOLT NEGATIVE GROUND.

(Check with your dealer if you are not sure.) Failure to do so may result in fire, etc.

---

### BEFORE WIRING, DISCONNECT THE CABLE FROM THE NEGATIVE BATTERY TERMINAL.

Failure to do so may result in electric shock or injury due to electrical shorts.

---

### DO NOT ALLOW CABLES TO BECOME ENTANGLED IN SURROUNDING OBJECTS.

Arrange wiring and cables in compliance with the manual to prevent obstructions when driving. Cables or wiring that obstruct or hang up on places such as the steering wheel, gear lever, brake pedals, etc. can be extremely hazardous.

---

### DO NOT SPLICE INTO ELECTRICAL CABLES.

Never cut away cable insulation to supply power to other equipment. Doing so will exceed the current carrying capacity of the wire and result in fire or electric shock.

---

### DO NOT DAMAGE PIPE OR WIRING WHEN DRILLING HOLES.

When drilling holes in the chassis for installation, take precautions so as not to contact, damage or obstruct pipes, fuel lines, tanks or electrical wiring. Failure to take such precautions may result in fire.

---

### DO NOT USE BOLTS OR NUTS IN THE BRAKE OR STEERING SYSTEMS TO MAKE GROUND CONNECTIONS.

Bolts or nuts used for the brake or steering systems (or any other safety-related system), or tanks should NEVER be used for installations or ground connections. Using such parts could disable control of the vehicle and cause fire etc.

---

### KEEP SMALL OBJECTS SUCH AS BOLTS OR SCREWS OUT OF THE REACH OF CHILDREN.

Swallowing them may result in serious injury. If swallowed, consult a physician immediately.

---

### DO NOT INSTALL IN LOCATIONS WHICH MIGHT HINDER VEHICLE OPERATION, SUCH AS THE STEERING WHEEL OR GEARSHIFT.

Doing so may obstruct forward vision or hamper movement etc. and results in serious accident.

## Caution

---

### HAVE THE WIRING AND INSTALLATION DONE BY EXPERTS.

The wiring and installation of this unit requires special technical skill and experience. To ensure safety, always contact the dealer where you purchased this product to have the work done.

---

### USE SPECIFIED ACCESSORY PARTS AND INSTALL THEM SECURELY.

Be sure to use only the specified accessory parts. Use of other than designated parts may damage this unit internally or may not securely install the unit in place. This may cause parts to become loose resulting in hazards or product failure.

---

### ARRANGE THE WIRING SO IT IS NOT CRIMPED OR PINCHED BY A SHARP METAL EDGE.

Route the cables and wiring away from moving parts (like the seat rails) or sharp or pointed edges. This will prevent crimping and damage to the wiring. If wiring passes through a hole in metal, use a rubber grommet to prevent the wires insulation from being cut by the metal edge of the hole.

---

### DO NOT INSTALL IN LOCATIONS WITH HIGH MOISTURE OR DUST.

Avoid installing the unit in locations with high incidence of moisture or dust. Moisture or dust that penetrates into this unit may result in product failure.

---

## Precautions

- Be sure to disconnect the cable from the (-) battery post before installing your VPA-B222. This will reduce any chance of damage to the unit in case of a short-circuit.
- Be sure to connect the color coded leads according to the diagram. Incorrect connections may cause the unit to malfunction or damage to the vehicle's electrical system.
- When making connections to the vehicle's electrical system, be aware of the factory installed components (e.g. on-board computer). Do not tap into these leads to provide power for this unit. When connecting the VPA-B222 to the fuse box, make sure the fuse for the intended circuit of the VPA-B222 has the appropriate amperage. Failure to do so may result in damage to the unit and/or the vehicle. When in doubt, consult your Alpine dealer.
- The VPA-B222 uses female RCA-type jacks for connection to other units (e.g. amplifier) having RCA connectors. You may need an adaptor to connect other units. If so, please contact your authorized Alpine dealer for assistance.
- Be sure to connect the speaker (-) leads to the speaker (-) terminal. Never connect left and right channel speaker cables to each other or to the vehicle body.

---

#### IMPORTANT

Please record the serial number of your unit in the space provided below and keep it as a permanent record. The serial number plate is located on the bottom of the unit.

SERIAL NUMBER: \_\_\_\_\_  
INSTALLATION DATE: \_\_\_\_\_  
INSTALLATION TECHNICIAN: \_\_\_\_\_  
PLACE OF PURCHASE: \_\_\_\_\_

# Installation

## Installing the unit

### Caution

- Do not block the unit's fan or heat sink, thus preventing air circulation. If blocked, heat will accumulate inside the unit and may cause a fire.
- Do not touch the heat sink as it becomes hot, and may result in injury.

### Air ventilation hole



<Side of the tuner box>

### When mounting with Velcro fasteners

When mounting the unit with the Velcro fasteners, be sure to choose a flat location.

Do not hang the unit from the bottom of the dashboard or rear deck with the Velcro fasteners.

- 1 Remove the Protective paper and attach two pieces of Velcro fastener to the bottom of the Tuner.

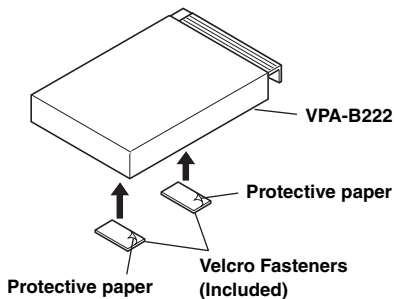

- 2 Check the position, and then fix the Tuner to the floor carpet.

### When mounting with Screws

When mounting the tuner with the screws, be sure to choose a flat location.

When making holes, be careful not to scratch any pipes or wires.

- 1 Connect the bracket to both the flanks of the tuner with the supplied pan screws (M4 × 8).

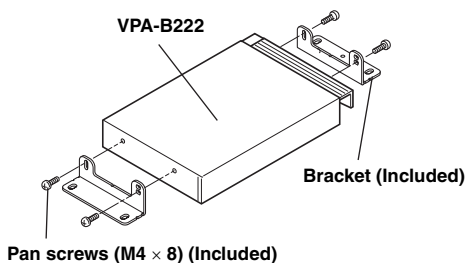

- 2 Install the tuner on the floor with the supplied flange-head tapping screws (M4 × 14).

### Flange-head tapping screws (M4 × 14) (Included)

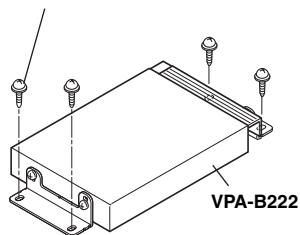

## Mounting the Commander

For safe use, make sure of the following:

- Location is stable and firm.
- Driver's view or operations are not obstructed.
- Located where driving can easily be performed (center console, etc.).  
During operation, ensure that your driving posture does not change, or that your attention is not taken away from safely driving your vehicle.

### 1 Confirm where the holder is to be placed, and determine its direction.

The angle of the commander can be adjusted according to the direction of the holder.

#### Pattern 1

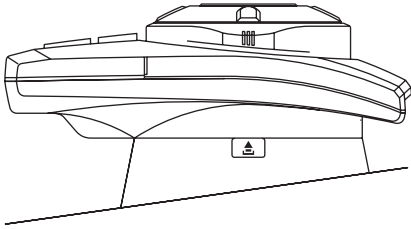

#### Pattern 2

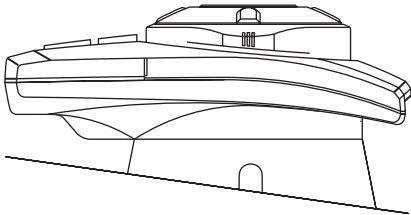

### 2 Route the commander connection cable through the holder.

#### Pattern 1

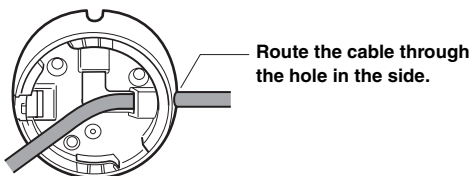

#### Pattern 2

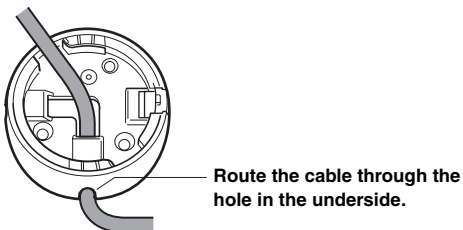

### 3 Mount the Holder

- When the holder cannot be mounted securely with double-sided adhesive tape, mount it by using screws.

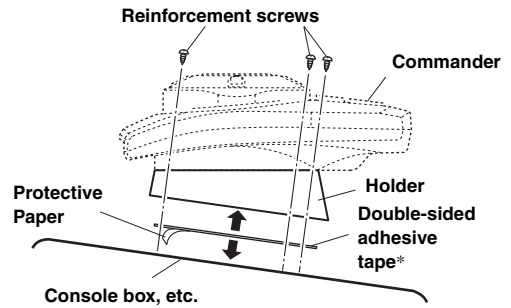

\*Before attaching the tape, make sure the mounting location is free from dust or dirt.

### 4 Connect the commander cable to the commander.

### 5 Take up any slack by pulling the cable, while holding the holder.

### 6 Set the commander on the holder.

After aligning the 2 projections on the backside of the commander with the groove of the holder, turn the commander clockwise until it clicks.

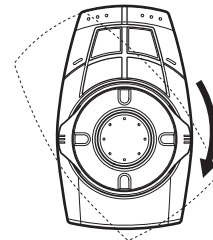
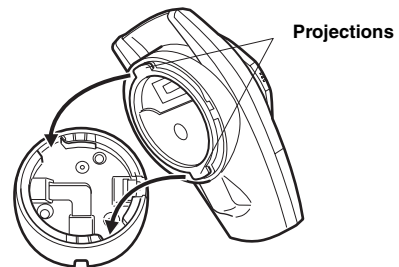

- When you remove the commander from the holder, turn the commander counterclockwise by pressing  on the holder, then remove the commander.



#### WARNING

**DO NOT INSTALL THE COMMANDER NEAR THE PASSENGER AIR BAG.**

If the unit is not installed correctly, the air bag may not function correctly, and if the air bag is triggered, parts may spring upwards and cause accident or injury.

### 7 Fix the connection cable with the supplied cable clamp.

## Parking Brake Lead Connection

If necessary, use a pinch connector to connect the foot brake lead, parking brake lead, etc.

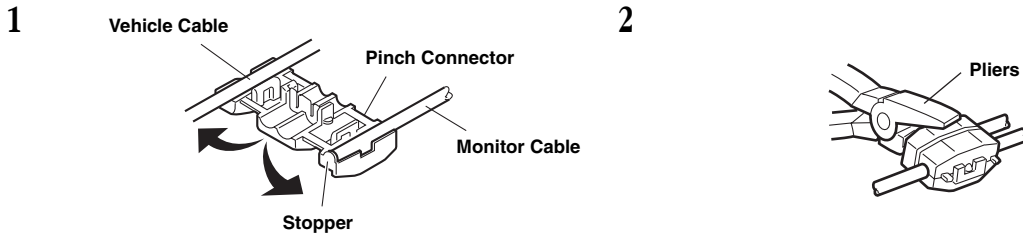

## Foot Brake Lead / Parking Brake Lead Connection

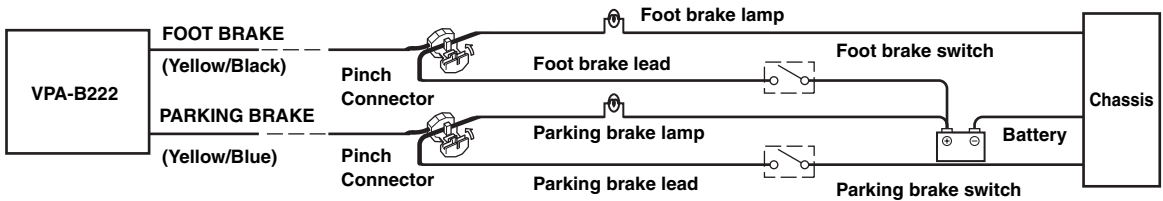

## Connection Diagram of SPST Switch (Sold Separately)

(If the ACC power supply is not available)

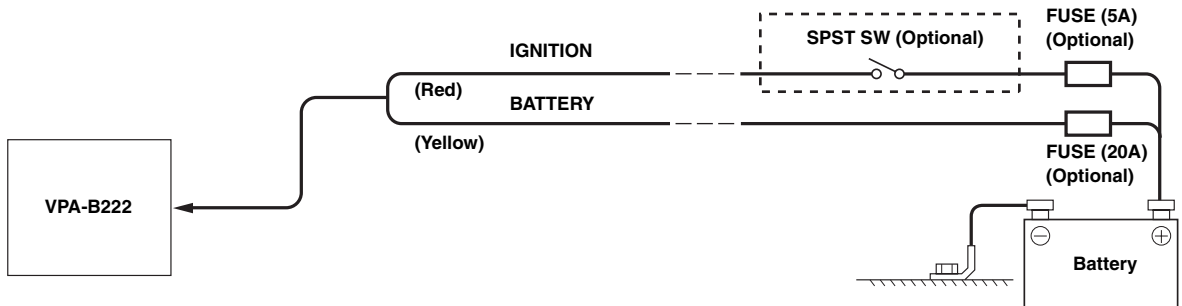

- If your vehicle has no ACC power supply, add an SPST (Single-Pole, Single-Throw) switch (sold separately) and fuse (sold separately).
- The diagram and the fuse amperage shown above are in the case when VPA-B222 is used individually.
- If the switched power (ignition) lead of the VPA-B222 is connected directly to the positive (+) post of the vehicle's battery, the VPA-B222 draws some current (several hundred milliamperes) even when its switch is placed in the OFF position and the battery may be discharged.

## Speaker Input Lead Connection

1 Cut the car audio's speaker leads.

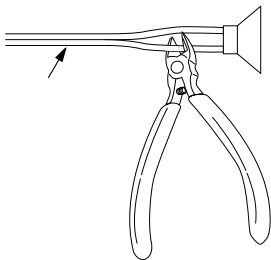

2 Connect the leads together.

Connect the supplied pinch connector.

### To prevent external noise from entering the audio system.

- Locate the unit and route the leads at least 10 cm away from the car harness.
- Keep the battery power leads as far away from other leads as possible.
- Connect the ground lead securely to a bare metal spot (remove any paint, dirt or grease if necessary) of the car chassis.
- If you add an optional noise suppressor, connect it as far away from the unit as possible. Your Alpine dealer carries various noise suppressors, contact them for further information.
- Your Alpine dealer knows best about noise prevention measures so consult your dealer for further information.

# Connections (VPA-B222 Wiring Diagram)

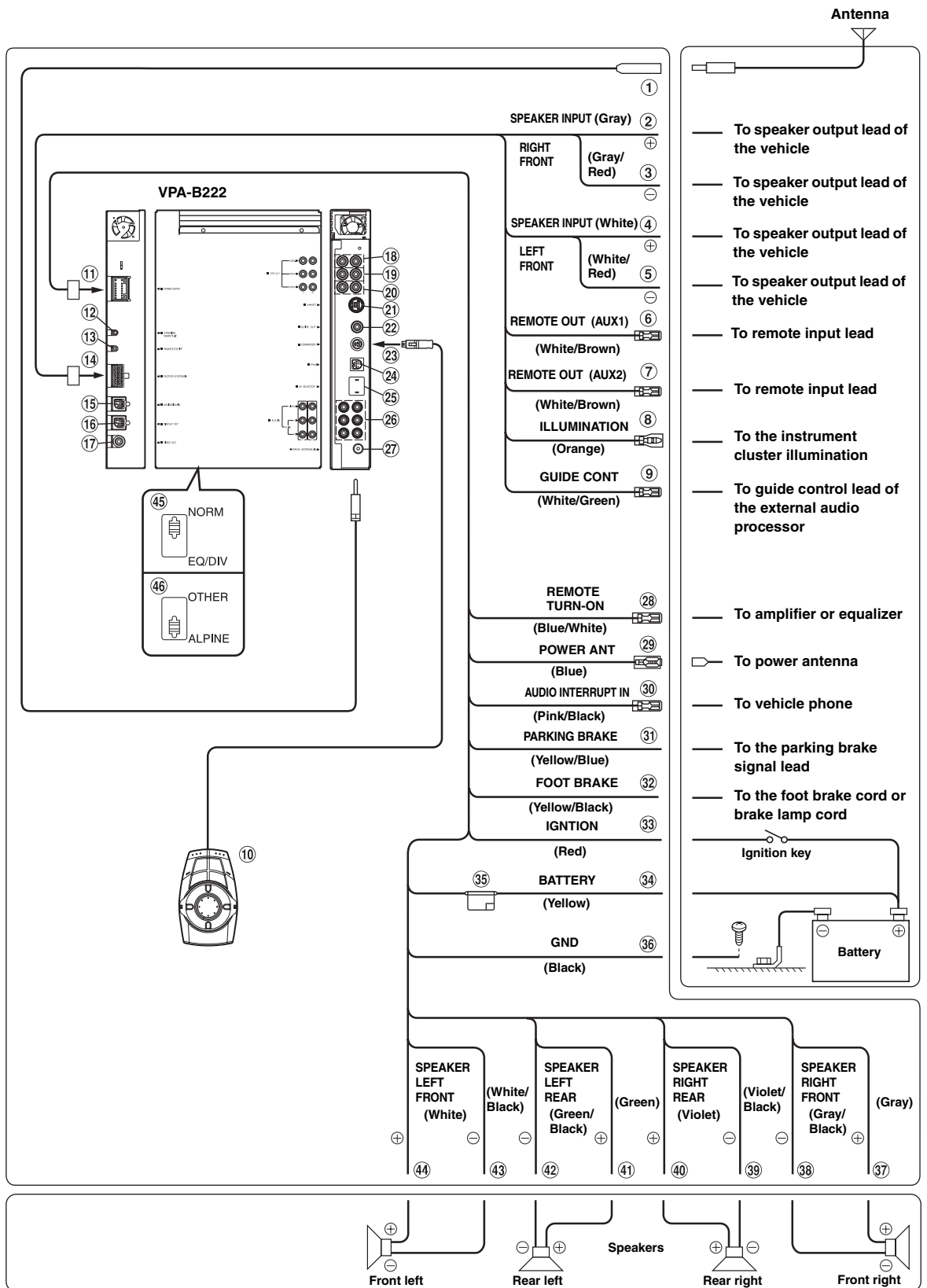

• Set the system switch to "NORM" when only a changer is connected (when the Ai-NET compatible equalizer is not used).

- ① **Antenna Extension Cable**
- ② **Right Front (+) Speaker Input Lead (Gray)**
- ③ **Right Front (-) Speaker Input Lead (Gray/Red)**
- ④ **Left Front (+) Speaker Input Lead (White)**
- ⑤ **Left Front (-) Speaker Input Lead (White/Red)**
- ⑥ **Remote Control Output Lead (White/Brown)**  
Connect this lead to the remote control input lead. This lead outputs the controlling signals from the remote control.
- ⑦ **Remote Control Output Lead (White/Brown)**  
Connect this lead to the remote control input lead. This lead outputs the controlling signals from the remote control.
- ⑧ **Illumination Lead (Orange)**  
This lead may be connected to the vehicle's instrument cluster illumination lead. This will allow the backlighting of the commander to dim whenever the vehicle's lights are turned on.
- ⑨ **Guide Control Lead (White/Green)**  
If an external audio processor is connected, connect this to the guide control lead.
- ⑩ **Commander (Included)**
- ⑪ **Power Supply Connector**
- ⑫ **Steering Remote Control Interface Connector**  
To steering remote control interface box.
- ⑬ **Remote Control Eye Jack**  
Connect this to the remote control sensor unit.
- ⑭ **Factory System Input Terminal**
- ⑮ **Navigation Input (RGB Input) Terminal**  
Connect this to the RGB output terminal of the Navigation System.
- ⑯ **Display Output (RGB Output) Terminal**  
Connect a 13P RGB terminal equipped monitor using the RGB cable supplied with the unit.
- ⑰ **Video Output Terminal**  
Connect this to the external front monitor using the RCA extension cable supplied with the unit.
- ⑱ **Subwoofer output Terminal**  
Connect the input lead of an amplifier for the subwoofer to this terminal.
- ⑲ **Rear output Terminal**  
Use when connecting an amplifier or equalizer.
- ⑳ **Front output Terminal**  
Use when connecting an amplifier or equalizer.
- ㉑ **Ai-NET Connector**  
Connect this to the output or input connector of other product (CD changer, Equalizer, etc.) equipped with Ai-NET.
- ㉒ **Guide Output Terminal**  
If an external audio processor is connected, outputs the navigation interrupt voice signal that is input from the Alpine navigation system, or the speaker input terminal.
- ㉓ **Commander Terminal**
- ㉔ **iPod Direct Connector**  
Control iPod signals.  
Connect this to an iPod, using the (also separately sold) FULL SPEED™ Connection Cable (KCE-422i).
- ㉕ **AV Select Connector**  
When this connector is connected to the optional expansion box (VPE-S431), connect this to the HEAD UNIT terminal of VPE-S431.
- ㉖ **AUX Input Terminals**  
If these terminals are connected to the optional expansion box (VPE-S431), the AUX input terminals are not used on this unit. Connect AUX IN 1, 2 and 3, and the AUX OUT 1 and 2 terminals of the expansion box (VPE-S431) to the external device(s).
- ㉗ **Antenna Receptacle**
- ㉘ **Remote Turn-On Lead (Blue/White)**  
Connect this lead to the remote turn-on lead of your amplifier or signal processor.
- ㉙ **Power Antenna Lead (Blue)**  
Connect this lead to the +B terminal of your power antenna, if applicable.
- ㉚ **Audio Interrupt In Lead (Pink/Black)**
- ㉛ **Parking Brake Lead (Yellow/Blue)**  
Connect this lead to the power supply side of the parking brake switch to transmit the parking brake status signals to the VPA-B222.
- ㉜ **Foot Brake Lead (Yellow/Black)**  
Connect to the vehicle's foot brake lead or brake lamp lead.
- ㉝ **Switched Power Lead (Ignition) (Red)**  
Connect this lead to an open terminal on the vehicle's fuse box or another unused power source which provides (+) 12V only when the ignition is turned on or in the accessory position.
- ㉞ **Battery Lead (Yellow)**  
Connect this lead to the positive (+) post of the vehicle's battery.
- ㉟ **Fuse Holder (10A)**
- ㊱ **Ground Lead (Black)**  
Connect this lead to a good chassis ground on the vehicle. Make sure the connection is made to bare metal and is securely fastened using the sheet metal screw provided.
- ㊲ **Right Front (+) Speaker Output Lead (Gray)**
- ㊳ **Right Front (-) Speaker Output Lead (Gray/Black)**
- ㊴ **Right Rear (-) Speaker Output Lead (Violet/Black)**
- ㊵ **Right Rear (+) Speaker Output Lead (Violet)**
- ㊶ **Left Rear (+) Speaker Output Lead (Green)**
- ㊷ **Left Rear (-) Speaker Output Lead (Green/Black)**
- ㊸ **Left Front (-) Speaker Output Lead (White/Black)**
- ㊹ **Left Front (+) Speaker Output Lead (White)**
- ㊺ **System Switch**  
When connecting an equalizer or divider using Ai-NET feature, place this switch in the EQ/DIV position. When no device is connected, leave the switch in the NORM position.
  - *Be sure to turn the power off on the unit before changing the switch position.*
- ㊻ **ALPINE/OTHER switching button**  
Set to "ALPINE" for normal use.  
Set to "OTHER" when connecting optional display interface box.

# System Example

## Connect the ALPINE Monitor

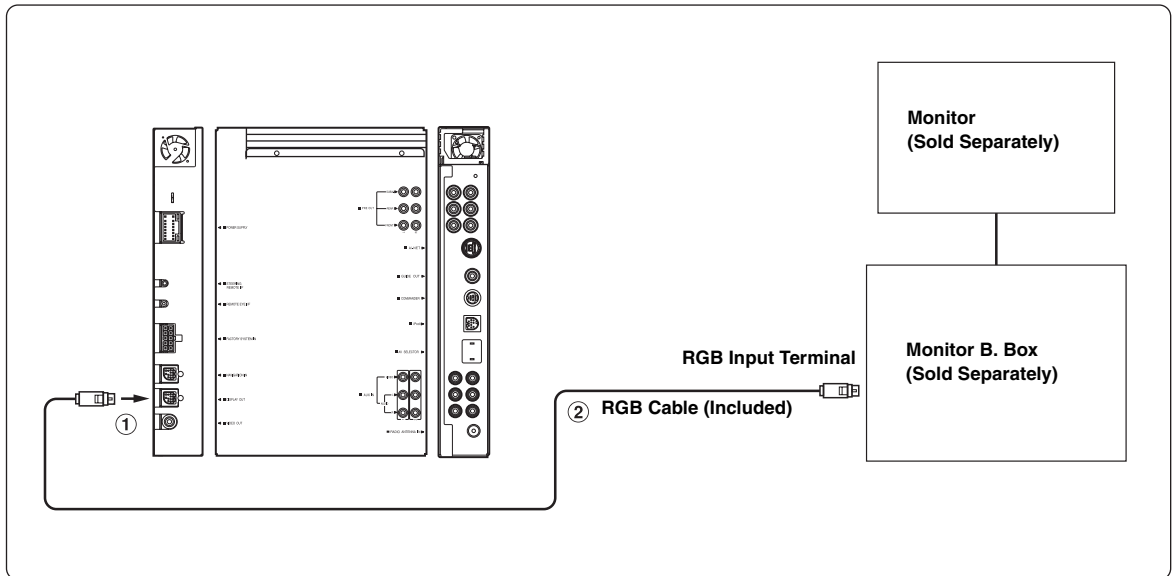

① **Display Output (RGB Output) Terminal**

Connect a 13P RGB terminal equipped monitor using the RGB cable supplied with the unit.

② **RGB Cable (Included)**

## Connect a Monitor of another manufacturer

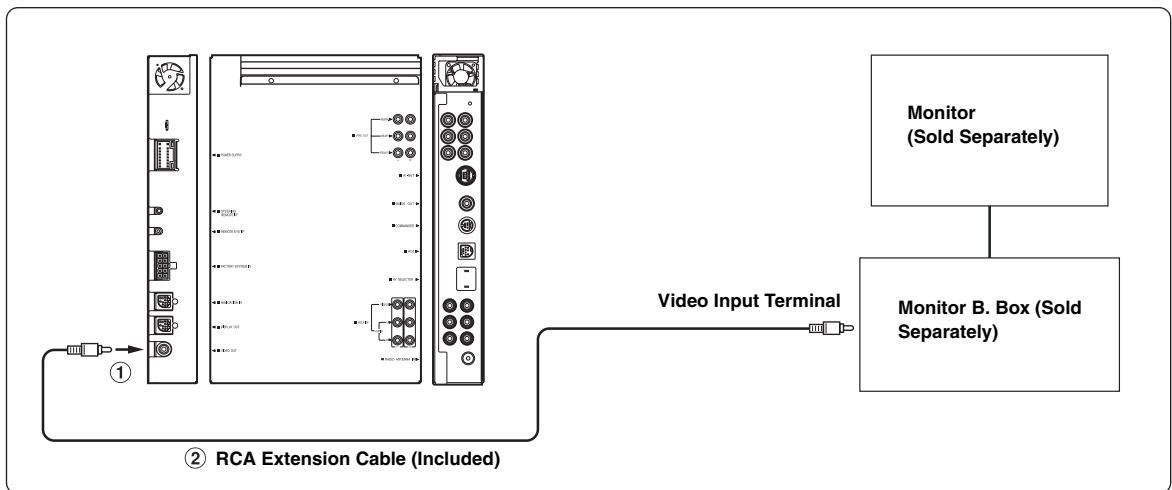

• Remote control sensor is required.

① **Video Output Terminal**

Connect this to the external front monitor using the RCA extension cable supplied with the unit.

② **RCA Extension Cable (Included)**



**Connect the Ai-NET compatible audio processor, Navigation system, DVD player and changer.**

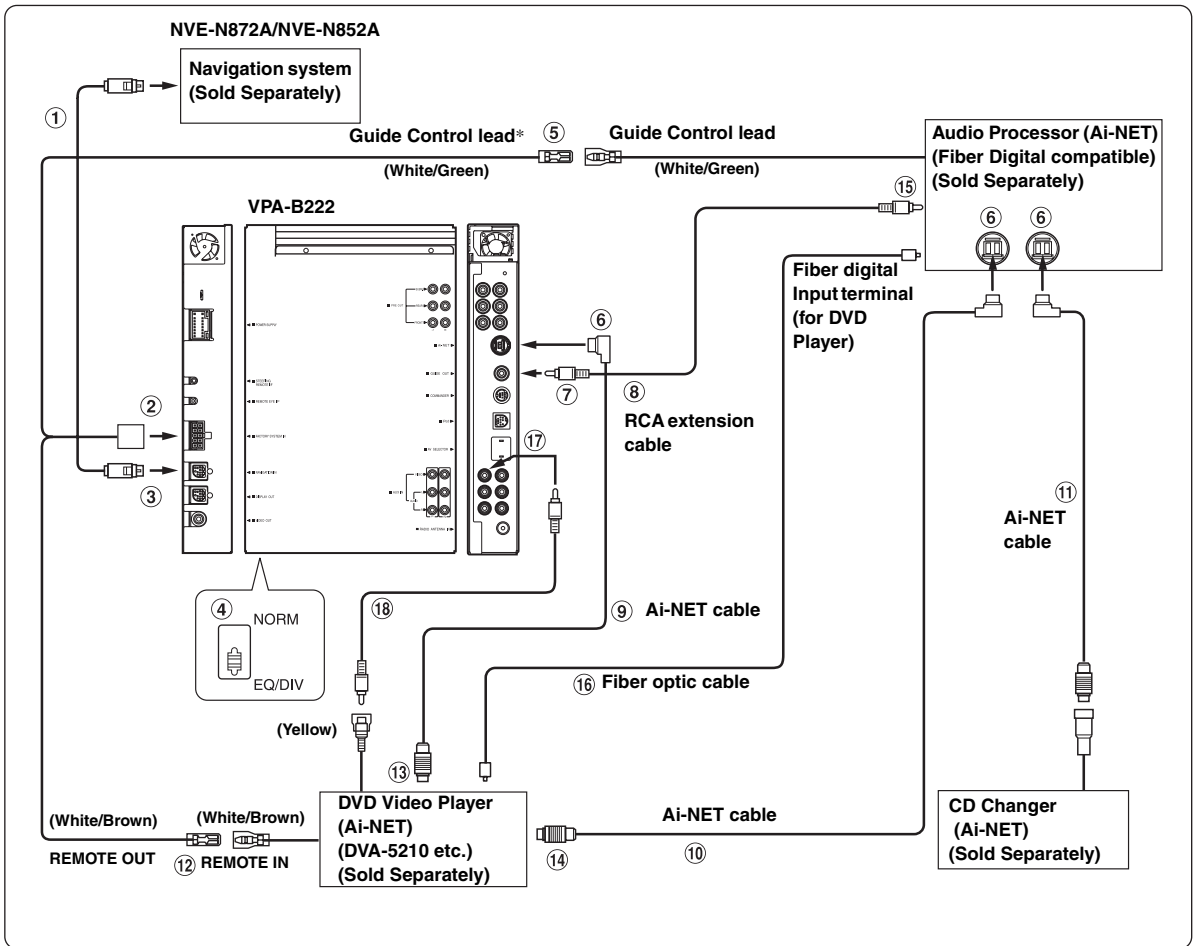

\* Guide Control lead is not connected when PXA-H700/PXA-H701 is connected.

- When the NVA-N751AS is connected for the Navigation System, use the RGB conversion cable KWE-503N (Sold separately).

- |   |   |
|---|---|
| <p>① <b>RGB Cable (Included with NVE-N872A/NVE-N852A)</b></p> <p>② <b>Factory System Input Terminal</b></p> <p>③ <b>Navigation Input (RGB Input) Terminal</b><br/>Connect this to the RGB output terminal of the Navigation System.</p> <p>④ <b>System Switch</b><br/>When connecting an equalizer or divider using Ai-NET feature, place this switch in the EQ/DIV position. When no device is connected, leave the switch in the NORM position.<br/>• Be sure to turn the power off on the unit before changing the switch position.</p> <p>⑤ <b>Guide Control Lead (White/Green)</b></p> <p>⑥ <b>Ai-NET Connector</b><br/>Connect this to the output or input connector of other products equipped with Ai-NET.</p> <p>⑦ <b>Guide Output Terminal</b><br/>If an external audio processor is connected, outputs the navigation interrupt voice signal that is input from the Alpine navigation system, or the speaker input terminal.</p> | <p>⑧ <b>RCA Extension Cable (Sold Separately)</b></p> <p>⑨ <b>Ai-NET Cable (Included with DVD video player)</b></p> <p>⑩ <b>Ai-NET Cable (Included with Audio Processor)</b></p> <p>⑪ <b>Ai-NET Cable (Included with CD Changer)</b></p> <p>⑫ <b>Remote Control Output Lead (White/Brown)</b><br/>Connect this lead to the remote control input lead. This lead outputs the controlling signals from the remote control.</p> <p>⑬ <b>To Ai-NET Connector (Gray)</b></p> <p>⑭ <b>To Ai-NET Connector (Black)</b></p> <p>⑮ <b>Navigation Audio Input Jack (RCA Input)</b></p> <p>⑯ <b>Fiber Optic Cable (Sold Separately)</b></p> <p>⑰ <b>AUX Video Input (AUX1) Terminal</b><br/>Connect the video output lead of a DVD video player or DVD changer to this terminal.</p> <p>⑱ <b>RCA Extension Cable (Included with DVD video player)</b></p> |
|---|---|

## When Connecting External Equipment

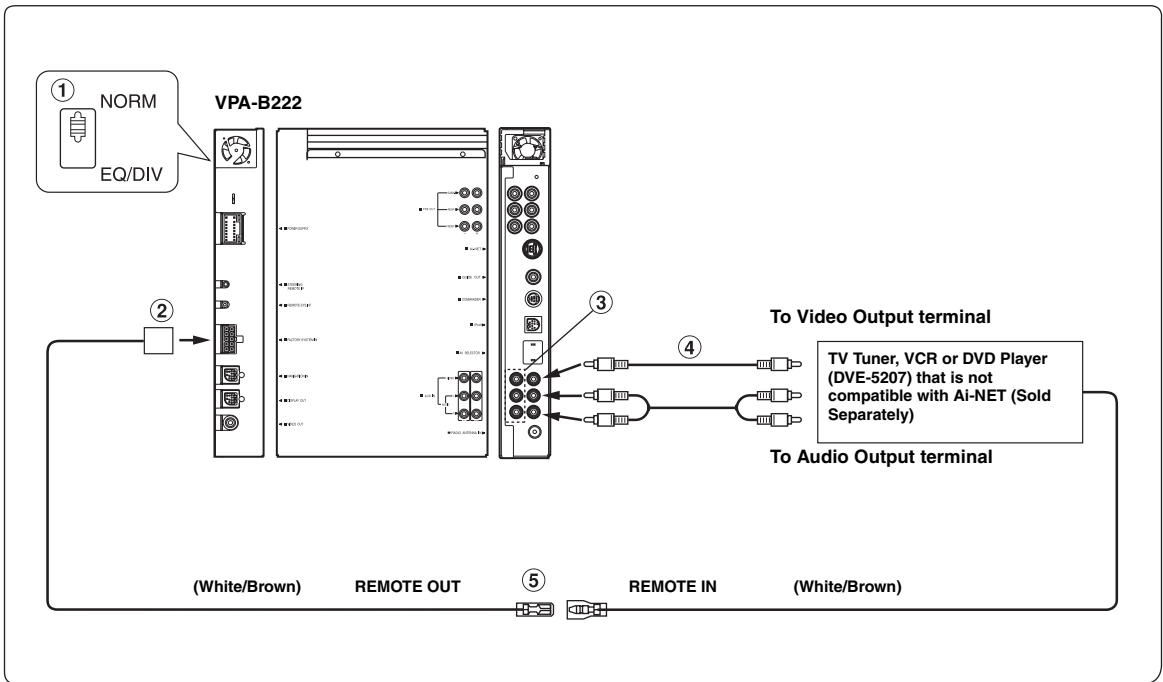

### ① System Switch

When connecting an equalizer or divider using Ai-NET feature, place this switch in the EQ/DIV position. When no device is connected, leave the switch in the NORM position.

- Be sure to turn the power off on the unit before changing the switch position.

### ② Factory System Input Terminal

### ③ AUX Video/Audio Input Terminal

### ④ RCA Extension Cable (Sold separately)

### ⑤ Remote Control Output Lead (White/Brown)

Connect this lead to the remote control input lead. This lead outputs the controlling signals from the remote control.

**Connect an expansion box (VPE-S431), DVD Player, DVD Changer or a Touch Panel-compatible Monitor.**

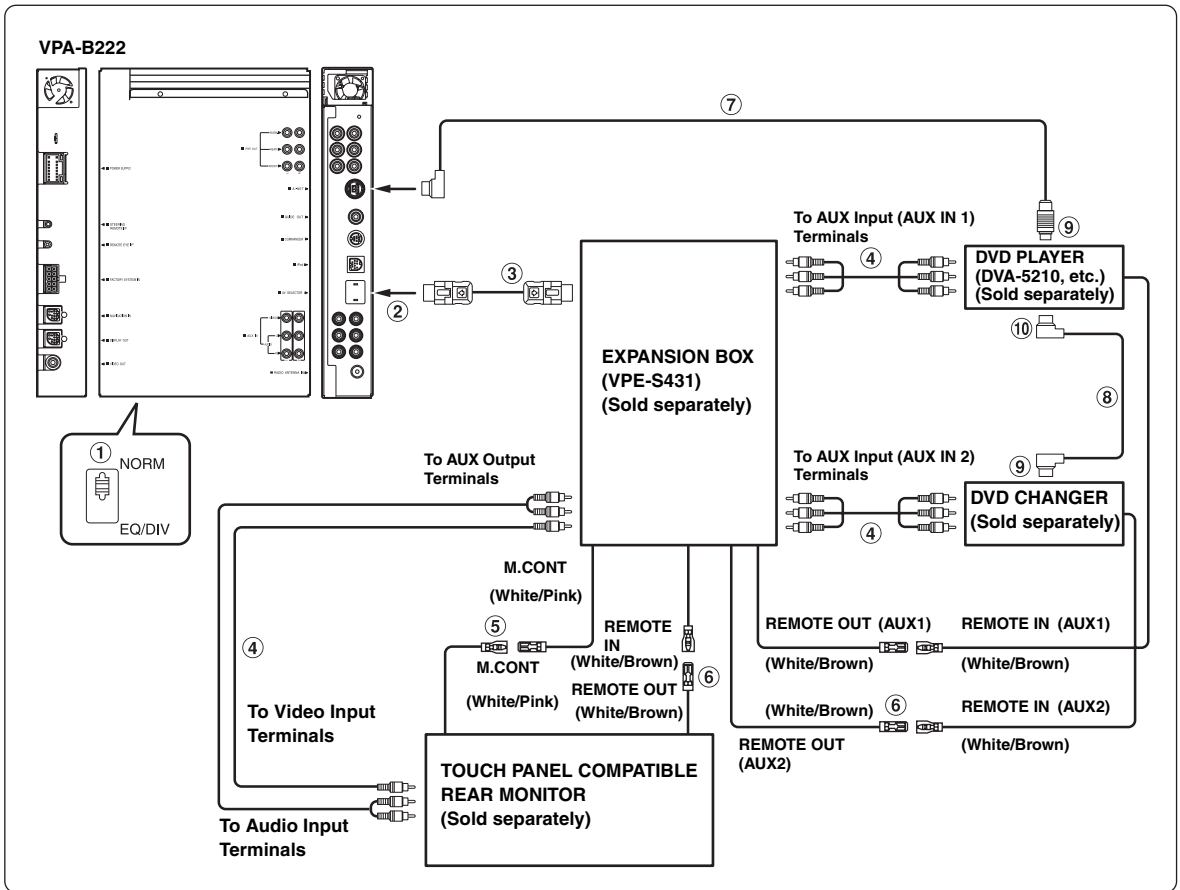

- If the expansion box (VPE-S431) is connected to either a DVD video player or DVD changer, connect this to AUX IN 1. If this is connected to AUX IN 2, remote control operation will not be possible. If both are to be connected, connect the DVD video player to AUX IN 1, and the DVD changer to AUX IN 2.

**① System Switch**

When connecting an equalizer or divider using Ai-NET feature, place this switch in the EQ/DIV position. When no device is connected, leave the switch in the NORM position.

- Be sure to turn the power off on the unit before changing the switch position.

**② To AV Selector Terminal**

**③ AV Selector Cable (Included with VPE-S431)**

**④ RCA Extension Cable (Sold separately)**

**⑤ Monitor Control Lead (White/Pink)**

Connect this to the Monitor Control Lead of the touch panel-compatible rear monitor.

**⑥ Remote Control Output Lead (White/Brown)**

Connect this lead to the remote control input lead. This lead outputs the controlling signals from the remote control.

**⑦ Ai-NET Cable (Included with DVD video player)**

**⑧ Ai-NET Cable (Included with DVD changer)**

**⑨ To Ai-NET Connector (Black)**

**⑩ To Ai-NET Connector (Gray)**

**Connect the car system (standard audio system, etc.).**

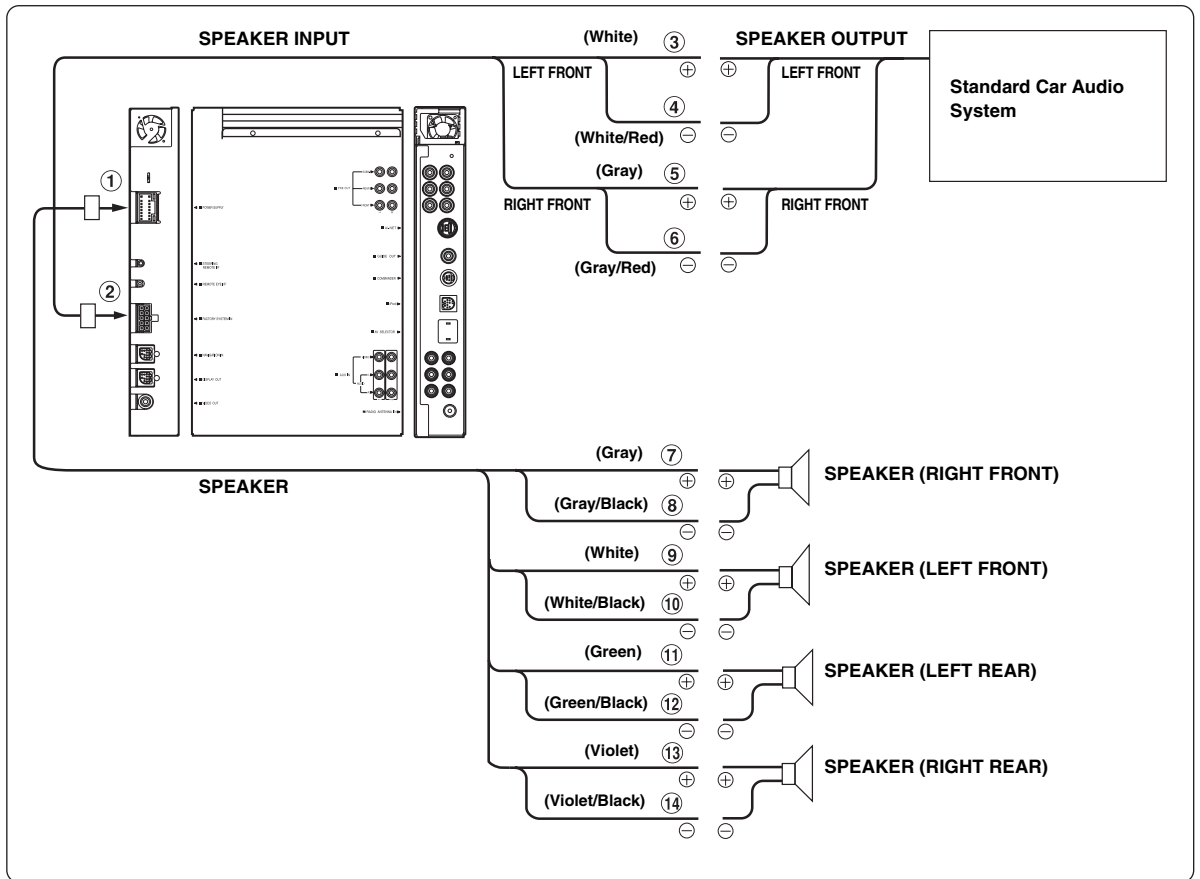

- |   |   |
|---|---|
| ① Power Supply Connector                        | ⑧ Right Front (-) Speaker Output Lead (Gray/Black)  |
| ② Factory System Input Terminal                 | ⑨ Left Front (+) Speaker Output Lead (White)        |
| ③ Left Front (+) Speaker Input Lead (White)     | ⑩ Left Front (-) Speaker Output Lead (White/Black)  |
| ④ Left Front (-) Speaker Input Lead (White/Red) | ⑪ Left Rear (+) Speaker Output Lead (Green)         |
| ⑤ Right Front (+) Speaker Input Lead (Gray)     | ⑫ Left Rear (-) Speaker Output Lead (Green/Black)   |
| ⑥ Right Front (-) Speaker Input Lead (Gray/Red) | ⑬ Right Rear (+) Speaker Output Lead (Violet)       |
| ⑦ Right Front (+) Speaker Output Lead (Gray)    | ⑭ Right Rear (-) Speaker Output Lead (Violet/Black) |

- Be sure to connect the speaker input lead to the front speaker output lead. The rear speaker output lead cannot be connected.
- Be sure to disconnect all the speaker output lead of the standard speaker and system.
- If a multi-channel speaker system is connected, connect the speaker input to the mid range speaker (front). If a tweeter or woofer is connected, sound will not be output correctly.
- Set each item in "Using the Speaker Input" (page 14).
- Refer to "Speaker Input Lead Connection" (page 51).
- Failure to connect correctly may result in damage to your standard car audio system.



## LIMITED WARRANTY

ALPINE ELECTRONICS OF AMERICA, INC. AND ALPINE OF CANADA INC. ("Alpine"), are dedicated to quality craftsmanship and are pleased to offer this Warranty. We suggest that you read it thoroughly. Should you have any questions, please contact your Dealer or contact Alpine at one of the telephone numbers listed below.

### ● PRODUCTS COVERED:

This Warranty covers Car Audio Products and Related Accessories ("the product"). Products purchased in the Canada are covered only in the Canada. Products purchased in the U.S.A. are covered only in the U.S.A.

### ● LENGTH OF WARRANTY:

This Warranty is in effect for one year from the date of the first consumer purchase.

### ● WHO IS COVERED:

This Warranty only covers the original purchaser of the product, who must reside in the United States, Puerto Rico or Canada.

### ● WHAT IS COVERED:

This Warranty covers defects in materials or workmanship (parts and labor) in the product.

### ● WHAT IS NOT COVERED:

This Warranty does not cover the following:

- ① Damage occurring during shipment of the product to Alpine for repair (claims must be presented to the carrier).
- ② Damage caused by accident or abuse, including burned voice coils caused by over-driving the speaker (amplifier level is turned up and driven into distortion or clipping). Speaker mechanical failure (e.g. punctures, tears or rips). Cracked or damaged LCD panels. Dropped or damaged hard drives.
- ③ Damage caused by negligence, misuse, improper operation or failure to follow instructions contained in the Owner's manual.
- ④ Damage caused by act of God, including without limitation, earthquake, fire, flood, storms or other acts of nature.  
Any cost or expense related to the removal or reinstallation of the product.
- ⑤ Service performed by an unauthorized person, company or association.
- ⑥ Any product which has the serial number defaced, altered or removed.
- ⑦ Any product which has been adjusted, altered or modified without Alpine's consent.
- ⑧ Any product not distributed by Alpine within the United States, Puerto Rico or Canada.
- ⑨ Any product not purchased from an Authorized Alpine Dealer.

### ● HOW TO OBTAIN WARRANTY SERVICE:

- ① You are responsible for delivery of the product to an Authorized Alpine Service Center or Alpine for repair and for payment of any initial shipping charges. Alpine will, at its option, repair or replace the product with a new or reconditioned product without charge. If the repairs are covered by the warranty, and if the product was shipped to an Authorized Alpine Service Center or Alpine, Alpine will pay the return shipping charges.
- ② You should provide a detailed description of the problem(s) for which service is required.

- ③ You must supply proof of your purchase of the product.
- ④ You must package the product securely to avoid damage during shipment. To prevent lost packages it is recommended to use a carrier that provides a tracking service.

### ● HOW WE LIMIT IMPLIED WARRANTIES:

ANY IMPLIED WARRANTIES INCLUDING FITNESS FOR USE AND MERCHANTABILITY ARE LIMITED IN DURATION TO THE PERIOD OF THE EXPRESS WARRANTY SET FORTH ABOVE AND NO PERSON IS AUTHORIZED TO ASSUME FOR ALPINE ANY OTHER LIABILITY IN CONNECTION WITH THE SALE OF THE PRODUCT.

### ● HOW WE EXCLUDE CERTAIN DAMAGES:

ALPINE EXPRESSLY DISCLAIMS LIABILITY FOR INCIDENTAL AND CONSEQUENTIAL DAMAGES CAUSED BY THE PRODUCT. THE TERM "INCIDENTAL DAMAGES" REFERS TO EXPENSES OF TRANSPORTING THE PRODUCT TO THE ALPINE SERVICE CENTER, LOSS OF THE ORIGINAL PURCHASER'S TIME, LOSS OF THE USE OF THE PRODUCT, BUS FARES, CAR RENTALS OR OTHER COSTS RELATING TO THE CARE AND CUSTODY OF THE PRODUCT. THE TERM "CONSEQUENTIAL DAMAGES" REFERS TO THE COST OF REPAIRING OR REPLACING OTHER PROPERTY WHICH IS DAMAGED WHEN THIS PRODUCT DOES NOT WORK PROPERLY. THE REMEDIES PROVIDED UNDER THIS WARRANTY ARE EXCLUSIVE AND IN LIEU OF ALL OTHERS.

### ● HOW STATE/PROVINCIAL LAW RELATES TO THE WARRANTY:

This Warranty gives you specific legal rights, and you may also have other rights which vary from state to state and province to province. In addition, some states/provinces do not allow limitations on how long an implied warranty lasts, and some do not allow the exclusion or limitation of incidental or consequential damages. Accordingly, limitations as to these matters contained herein may not apply to you.

### ● IN CANADA ONLY:

This Warranty is not valid unless your Alpine car audio product has been installed in your vehicle by an Authorized Installation Center, and this warranty stamped upon installation by the installation center.

### ● HOW TO CONTACT CUSTOMER SERVICE:

Should the product require service, please call the following number for your nearest Authorized Alpine Service Center.

**CAR AUDIO 1-800-ALPINE-1 (1-800-257-4631)  
NAVIGATION 1-888-NAV-HELP (1-888-628-4357)**

Or visit our website at; <http://www.alpine-usa.com>

**ALPINE ELECTRONICS OF AMERICA, INC.**, 19145 Gramercy Place, Torrance, California 90501, U.S.A.

**ALPINE ELECTRONICS OF CANADA, INC.**, 7300 Warden Ave., Suite 203, Markham, Ontario L3R 9Z6, Canada  
Do not send products to these addresses.

Call the toll free telephone number or visit the website to locate a service center.